

# TECHNICAL & FINANCIAL FILE

TECHNICAL SUPPORT UNIT FOR WATER  
MANAGEMENT AND URBAN DEVELOPMENT IN  
RELATION TO CLIMATE CHANGE IN THE  
PROVINCES OF HA TINH, NINH THUAN AND BINH  
THUAN

VIETNAM

DGCD CODE : NN 3012430

NAVISON CODE : VIE 12 045 11

# TABLE OF CONTENTS

<b>ABBREVIATIONS .....</b>	<b>4</b>
<b>SUMMARY .....</b>	<b>6</b>
<b>ANALYTICAL RECORD OF THE INTERVENTION.....</b>	<b>7</b>
<b>1. SITUATION ANALYSIS.....</b>	<b>8</b>
1. 1. INTRODUCTION .....	8
1. 2. THE INSTITUTIONAL FRAMEWORK.....	9
1. 3. DONOR SUPPORT FOR CLIMATE CHANGE AND RELATED SECTORS .....	10
1. 4. BELGIAN SUPPORT TO INTEGRATED WATER MANAGEMENT AND URBAN DEVELOPMENT IN RELATION TO CLIMATE CHANGE.....	10
<b>2. STRATEGIC ORIENTATIONS .....</b>	<b>12</b>
2. 1. UNDERLYING PRINCIPLES.....	12
2. 2. ROLE AND COMPOSITION OF TSU.....	12
2. 3. INSTITUTIONAL ANCHORAGE .....	14
2. 4. NETWORKING AND INVOLVEMENT OF OTHER DEVELOPMENT PARTNERS .....	15
<b>3. INTERVENTION FRAMEWORK .....</b>	<b>16</b>
3. 1. GENERAL OBJECTIVE .....	16
3. 2. SPECIFIC OBJECTIVE.....	16
3. 3. EXPECTED RESULTS AND ACTIVITIES.....	16
3. 4. INDICATORS AND MEANS OF VERIFICATION .....	19
3. 5. RISKS .....	21
<b>4. RESOURCES .....</b>	<b>24</b>
4. 1. BUDGET .....	24
4. 2. HUMAN RESOURCES .....	24
4. 3. MATERIAL & EQUIPMENT .....	25
<b>5. IMPLEMENTATION MODALITIES .....</b>	<b>29</b>

5. 1.	IMPLEMENTATION AND FOLLOW-UP STRUCTURES.....	29
5. 2.	COORDINATION MECHANISMS.....	31
5. 3.	MANAGEMENT MODALITIES.....	31
5. 4.	REPORTING.....	35
<b>6.</b>	<b>CROSS CUTTING THEMES.....</b>	<b>37</b>
6. 1.	ENVIRONMENT.....	37
6. 2.	GENDER.....	38
<b>7.</b>	<b>ANNEXES.....</b>	<b>39</b>
7. 1.	PLANNING TSU.....	39
7. 2.	TOR LONG-TERM PERSONNEL.....	42

## ABBREVIATIONS

ADB	Asian Development Bank
AFD	Agence Française de Développement
BTC	Belgian Technical Co-operation
CC	Climate Change
DSENRE	Department of Science, Education, Natural Resources and Environment - MPI
GESF	Green Economy Strategy Facility
IWRM	Integrated Water Resource Management
JICA	Japanese International Cooperation Agency
M&E	Monitoring and Evaluation
MoC	Ministry of Construction
MoF	Ministry of Finance
MoHA	Ministry of Home Affairs
MoNRE	Ministry of Natural Resources and Environment
MPI	Ministry of Planning and Investment
MTR	Midterm Review
NTP-RCC	National Target Programme for Response to Climate Change
ODA	Official Development Aid
PCU	Project Coordination Unit
POM	Project Operation Manual

PPC	Provincial People's Committee
SAV	State audit of Vietnam
SC	Steering Committee
SPRCC	Support Programme to Respond to Climate Change
TFF	Technical and Financial File
ToR	Terms of Reference
TSU	Technical Support Unit
UN REDD	UN Collaborative Programme on Reducing Emissions from Deforestation and Forest Degradation in Developing Countries
UNDP	United Nations Development Programme
UNEP	UN Environment Programme
UNFCCC	United Nations Framework Convention on Climate Change
VUDA	Vietnam Urban Development Agency - MoC
VUF	Vietnam Urban Forum
WB	World Bank

## SUMMARY

Viet Nam is confronted with the impact of climate change, which if not adequately addressed, could seriously hinder the countries sustainable development and poverty alleviation efforts. At the same time Vietnamese cities have been subject to radical socio-economic and physical changes combined with a massive rural migration towards the cities, resulting in rapid population growth. Consequently in cities, water supply demand has rapidly increased and dealing with increased wastewater is a major challenge for city development, as the available urban infrastructure is not adapted.

In the following years, Belgium wants to support the Vietnamese water management and urban development in the coastal provinces of Ha Tinh, Ninh Thuan and Binh Thuan. A programme consisting of 3 projects at provincial level will contribute to the sustainable development and support water management and urban development in relation to Climate Change. The strategy of these projects will be based on a comprehensive approach taking into account the complexity of the topic. The programme aims to complement existing climate change strategies and action plans developed by local authorities by integrating in-depth studies, and to link the results of these studies with the urban strategic planning of selected cities, thereby increasing the resilience of the various settlements to meet the climate change. Capacity development and learning through the implementation of a number of strategic pilot experiences are expected to be the major outcomes. The project intends to stimulate the collaboration between the selected provinces and the relevant ministries for water management, urban development and green growth economy. These provincial projects will also benefit from a Technical Support Unit (TSU) based at central level.

The present Technical and Financial File describes how the technical support to the provinces will be assured through the TSU. The TSU should *strengthen the capacities in climate change management in relation to Integrated Water Resource Management and Urban Development*. The TSU will support the strategic orientations of the provincial projects, i.e. building resilience to climate change, integrate water resource management and support an appropriate urban planning approach. It is expected to obtain the following results:

- Timely and appropriately expertise is provided to the provinces of Ha Tinh, Ninh Thuan and Binh Thuan
- Co-ordination between central and provincial level is strengthened
- Knowledge management of the experiences is assured

## ANALYTICAL RECORD OF THE INTERVENTION

Intervention number	NN 3012430	
Navision Code BTC	VIE12 045 11	
Partner Institution	Ministry of Planning and Investment	
Duration of the intervention	72 months	Inception phase : 6 months Implementation phase : 60 months Closure phase : 6 months
Start of the intervention	November 2012	
Vietnamese Contribution	400,000 EUR (equivalent)	
Belgian Contribution	4,000,000 EUR	
Sector (DAC codes)	41010	
Brief description of the intervention	Through a Technical Support Unit (TSU), diverse technical expertise will be effectively and efficiently delivered to support the water management and urban development programmes in three provinces. At the same time, the TSU will become an important bridge to feed valuable lessons from provinces to policy making authorities at the central level in the field of water management, urban development and green growth economy in the perspective of climate change	
General Objective	To contribute to the sustainable development of Vietnam, by enhancing its resilience to Climate Change	
Specific Objective	To strengthen the capacities in climate change management of Vietnam in relation to Integrated Water Resource Management and Urban Development, in particular in the provinces of Ha Tinh, Ninh Thuan and Binh Thuan	
Results	R1: Timely and appropriately expertise is provided in a more cost-efficient way to the provinces of Ha Tinh, Ninh Thuan and Binh Thuan R2: Co-ordination between central and provincial level is strengthened R3: Knowledge management of the experiences is assured	

# 1. SITUATION ANALYSIS

## 1.1. INTRODUCTION

Vietnam is one of the world's most disaster prone countries. Floods regularly cause damage to infrastructure and significant losses in the agriculture and fisheries sector. The phenomenon of Climate Change is expected to result in increased disasters to Vietnam in the form of typhoons, cyclones, floods and droughts. Increased sea level threatens about 10% of the population of Vietnam. Climate change will also have an impact on water quality and influence ground water tables. In recent years Vietnam has already been confronted with evidence of consequences of climate change, and it is expected that this will continue in the coming years. Vietnam has a long tradition of designing and implementing adaptation projects especially regarding floods and cyclones, but the new trend will enforce it to rapidly introduce new measures. Therefore a National Target Programme to Respond to Climate Change has been developed.

At the same time Vietnamese cities have been subject to radical socio-economic and physical changes combined with a massive rural migration towards the cities. Vietnam has obtained remarkable results in its combat against poverty but the remaining urban poor are particular at risk of the above-mentioned threats. The gains of recent years risk to be undone. Urban areas are growing and will continue to do so. Consequently water supply demand has highly increased and cities have to deal with increased wastewater. The available infrastructure is not adapted to these new challenges. Furthermore, the spatial implications of appropriate water management within and around cities are often not sufficiently addressed, which leads to increased flooding and water scarcity risks.

To tackle the impact of climate change, a comprehensive approach is required, taking into account both mitigation and adaptation measures. The main challenges in the Vietnamese context are

- limited understanding of causes and effects
- weak institutional system to respond to the challenges
- appropriate policy development
- limited technology and experience
- struggle to transform the current economy into a low carbon economy
- limited dialogue between the authorities, the private sector and the communities

Viet Nam was a leader in the world in economic growth over the last ten years but realises that in order to guarantee sustainable development, it is essential to transform to a low carbon economy. As important Greenhouse Gas producers, cities have a major role to play in a strategy to diminish these emissions.

In the coming years, Belgium will support water management and urban development in the framework of climate change, in the coastal provinces of Ha Tinh, Ninh Thuan and Binh Thuan. A



programme consisting of 3 projects at provincial level will contribute to the sustainable development and support water management and urban development in relation to Climate Change. The strategy of these projects will be based on a comprehensive approach taking into account the complexity of the topic. The programme aims to complement existing climate change strategies and action plans developed by local authorities by integrating in-depth studies, while revising the master plans of selected cities in order to increase their resiliency to climate change. Capacity development and learning through the implementation of a number of strategic pilot experiences are expected to be the major outcomes. The project intends to stimulate the collaboration between the selected provinces and the relevant ministries for water management, urban development and green growth economy. These provincial projects will also benefit from a Technical Support Unit (TSU) based at central level. The present project defines the way how the TSU should provide complementary expertise to the selected provinces.

## **1. 2. THE INSTITUTIONAL FRAMEWORK**

The relevant institutional framework includes the frameworks for climate change, urban development and water management.

A National Target Programme for Response to Climate Change (NTP-RCC) has been elaborated to enhance the capacity and efficiency with set targets for the period 2010-2015. The objectives of NTP-RCC include assessment of effects of climate change, develop adequate action plans, taking opportunities to develop a low carbon economy and joining the international community's effort in mitigating the effects of Climate Change. In 2011, a National Climate Change strategy has been approved. A Support Programme to Respond to Climate Change (SPRCC) at provincial level involving different ministries has been established.

Over the last years, Vietnam has taken a number of decisions and commitments both at national and international level to provide an appropriate institutional framework for Climate Change. Vietnam signed the United Nations Framework Convention on Climate Change (UNFCCC) in 1992 and the Kyoto Protocol in 1998.

At provincial level, Master Plans for cities exist but have not been yet complemented by hydrology and meteorology studies, although Climate Change Action Plans at provincial level have been developed. The objectives of these plans include assessments of the socio-economic effects of climate change, improvement of the ability to react to its consequences and integration of Climate Change into provincial development strategies.

Over the last decade, the Government of Vietnam has issued a number of laws, decisions and decrees to regulate water management. Also the legal frameworks dealing with urban development, infrastructure management and environmental protection in areas has strongly developed over the last years, including the definition of technical standards and regulations. The National Strategy for Natural Disaster Prevention, Response and Mitigation is also relevant in the context of climate change.

Several technical ministries are covering the combination of urban development, water resource management and climate change issues. However considering the relatively new phenomenon of climate change, mandates of different ministries are not always clear or overlap. Policies dealing with urban development and water management in relation to climate change need to be

complemented and/or fine-tuned. The integration of climate change within the standards and norms for infrastructure works is still limited.

### **1. 3. DONOR SUPPORT FOR CLIMATE CHANGE AND RELATED SECTORS**

The international community as a whole has a strong interest in Climate Change.

The implementation of the of the national programme NTP-RCC has been funded through a Support Programme to Respond to Climate Change (SP-RCC) supported by Development Partners such as the Japanese International Cooperation Agency (JICA), Agence Française de Développement (Afd), Denmark and United Nations Development Programme (UNDP). In addition, the Ministry of Natural Resources and Environment (MoNRE) receives a lot of support at central level from various development partners.

The Asian Development Bank (ADB) and the World Bank (WB) have an important portfolio in the water and sanitation sector in urban settings and in relation to climate change. The United Nations is involved through a number of its agencies, including UN-habitat, UN Environment Programme (UNEP), UN Collaborative Programme on Reducing Emissions from Deforestation and Forest Degradation in Developing Countries (UN-REDD) and UNDP.

Ha Tinh Province is supported by the Asian Development Bank (ADB), IFAD and Norway. In recent past it has benefitted from support of DFID and UNDP. Through its support to the Natural Disasters Risk Management Project, also WB is involved.

Ninh Thuan Province is supported by ADB, and until recently by the Netherlands.

Binh Thuan Province is benefitting from support of the National Target Programme and a programme in Phan Ri - Phan Thiet funded by JICA.

### **1. 4. BELGIAN SUPPORT TO INTEGRATED WATER MANAGEMENT AND URBAN DEVELOPMENT IN RELATION TO CLIMATE CHANGE**

Over the last 15 years, Belgium has supported urban development of a number of Vietnamese cities, including water supply and sanitation, focused on poverty alleviation. Major interventions have been financed in Ho Chi Minh City, Ninh Thuan Province, Binh Thuan Province and Binh Dinh Province.

In the coming years, the Belgian contribution will focus the selected provinces of Ha Tinh, Ninh Thuan and Binh Thuan. The starting point are approved Climate Change Action Plans, which will be complemented by hydraulic and meteorological studies and modelling of selected river basins and revised master plans of selected cities and towns, considering climate change impacts. This should lead to a number of strategic pilot investments. The three projects will be managed by the provinces.

The intervention strategies for the 3 provincial interventions all focus on both mitigation and adaptation measures, essentially based on 10 elements:

- capacity development and institutional strengthening

- awareness raising
- data collection
- analysing and modelling
- complement Climate Change strategies
- integrate Climate Change in urban planning
- develop priority action plans
- resource mobilisation
- implementation of pilot projects
- feedback & knowledge management

Although the project activities will be specific for each provincial project, the expected results can be summarized in 4 domains:

- Development of capacity in Climate Change, Integrated Water Resource Management (IWRM) and urban development of the province and the cities involved in the program, with appropriate monitoring and evaluation mechanisms in place;
- Development of a comprehensive strategy on Climate Change based on various studies, including Climate Change and hydraulic modelling of one river catchment per province and the revision of the existing master plans of the cities involved, while key priorities of the Climate Change action plan of both urban centres defined;
- Development of strategic pilot activities in each province, with appropriate operational and maintenance modalities and disseminated lessons learned
- Active involvement of the communities and the private sector to support the provincial Climate Change strategy.

## **2. STRATEGIC ORIENTATIONS**

### **2.1. UNDERLYING PRINCIPLES**

A Technical Support Unit at central level should offer a number of advantages to the implementation of the provincial projects, i.e.:

- advantage of scale by providing a greater variety of expertise and an interdisciplinary team;
- strengthening the links between central and provincial level;
- addressing technical issues that go beyond the provincial dimension;
- enabling a comprehensive approach towards understanding and tackling the various challenges.

The TSU will respect the autonomy of the 3 provincial projects, in line with the legal framework of Vietnam, but at the same time it should guarantee coherence of the programme.

### **2.2. ROLE AND COMPOSITION OF TSU**

The TSU should be considered as a broker between the different stakeholders involved in Climate Change, urban development and water resource management, both at provincial and at central level. The TSU is the institutional, organizational and technical advisor of the project. In that respect, it will provide advice and capacity development support to the implementers at provincial level in order for them to realistically plan activities, target results, and follow the planning, outputs and outcomes of the project. The TSU will guarantee the general coherence of the program involving 3 Provinces and central level.

The TSU will in the first place support the implementation of the projects in the 3 selected provinces and can contribute in the application of all 10 elements of the strategy, i.e.:

- capacity development and institutional strengthening
- awareness raising
- data collection
- analysing and modelling
- complement Climate Change strategies
- integrate Climate Change in urban planning
- develop priority action plans
- resource mobilisation
- implementation of pilot projects
- feedback & knowledge management

The TSU will ensure the coordination between all interventions related to climate change supported by Belgium in terms of technical support, and is expected to:

- Support the province to define M&E methodology and tool for project monitoring, as well as similar baseline study for potential comparison between the 3 projects and to facilitate the project follow-up;
- Support the provinces to complement and implement approved Climate Change Action Plans and revise spatial master plans of selected towns, cities and river basin regions accordingly;
- Expose the 3 provinces to alternative solutions, innovation as well as worldwide and Vietnamese best practice related to CC, IWRM and urban development;
- Stimulate interaction between the selected provinces and ensure the overall coordination of the program and facilitate cooperation between the 3 provinces;
- Stimulate interaction between central level and provincial level and ensure coordination between the related technical ministries and the provinces;
- Stimulate collaboration between different departments and institutions at central level;
- Ensure the overall coherence of the 3 projects by maximizing the exchange of information between the 3 PCUs and the coordination of their respective activities;
- Ensure the coordination between the 3 provinces and the central level for the selection of similar CC/IWRM monitoring equipment and software among the 3 provinces, and be responsible for the development of customized software, their installation, their maintenance and upgrading;
- Favour the access of the 3 provinces to data and information at ministry level, and the dialogue between provincial and national levels;
- Favour linkage, exchange of information, joint activities between the 3 provinces;
- Initiate cooperation with other donors initiatives and advocate for complementary funding;
- Contribute to the capacity development of actors in the sectors of Climate Change, water resource management and urban development;
- Ensure the technical quality control of the tender documents initiated by the PCUs, the consultants input related to surveys, studies, modelling, feasibility studies, detail design and planning, as well as of the physical investment;
- Assure that experiences of the provinces serve as feedback to the policy makers;
- Favour the capitalisation of the lessons learned for feedback to policy level and produce concept notes and comparison analysis;
- Coordinate the dissemination of results from the 3 provinces;
- Facilitate the coordination of the CC program with the GEFS;
- Provide technical guidance to the Project Coordination Units (PCU) of the Provinces for the preparation of the documents to be submitted to BTC for non-objection.

An important challenge for the provincial projects is to assure that the study phase results in appropriate long-term investments. This goes beyond the Belgian support which will only launch strategic pilot investment projects. Therefore from the beginning of the intervention the TSU will have an important role in preparing the ground for these long-term investments through networking.

In order to be able to conduct their duties, the provinces shall support the TSU to have access to all required data, information, reports... related to the topics of the project and meet, under PCU coordination, whenever necessary the all the stakeholders involved in the project implementation (PCU, province agencies, district, commune authorities of the different river basins, mass organisations, community and private sectors representatives...). As to ensure the quality of the results, the TSU is also entitled to give, through the PCU, recommendations to the providers of services and construction works contracted by the project during the implementation of the activities. As the contracting authority, the PCU has the responsibility to verify the good execution of the recommendations by the services/works provider.

Furthermore, the PCUs will inform the TSU about the progress of the different technical activities necessary to the good execution of the project, and will share with the TSU all the related documents at key stages.

In case of conflict between the province experts and/or the PCU and the technical advices provided by the TSU either through the form of direct recommendations or a BCT official technical non objection, the SC will request the advice of an independent expert, selected by both parties.

Cross-cutting technical issues involving both central and provincial levels, should be addressed at the level of the ad hoc Technical Advisory Committee of the TSU (see TFF TSU).

To be able to live up to all these expectations, the TSU will be composed of:

- A number of Vietnamese experts from relevant Ministries involved in policy making. They will particularly ensure a smooth exchange of information and coordination between the CC program and their respective ministry;
- A number of long-term international and Vietnamese technical experts in the field of Climate Change, IWRM and urban planning. They will ensure, among others, the day-to-day support to the 3 provinces and respective ministries, give access to up-to-date related information and innovations, guide and control the quality of the work provided by the consultants recruited by the provinces and develop a knowledge management process for all the actors;
- In addition, there will be the possibility to temporarily extend the TSU with ad hoc expertise to respond to specific technical needs.

### **2. 3. INSTITUTIONAL ANCHORAGE**

The TSU will in the first place collaborate with ministries that are directly involved with policy making and implementation of issues related to water resource management and climate change in an urban setting, i.e.:

- the Ministry of Planning and Investment (MPI)

- Ministry of Natural Resources and Environment (MoNRE)
- Ministry of Construction (MoC)

The TSU will be integrated within the Department of Science, Education, Natural Resources and Environment (DSENRE) of MPI. Close link will be ensure with the two other ministries through different mechanisms described below.

As DSENRE is in charge of the green growth strategy and will host the GESF facility, for which Belgium will contribute 5 million, it could further enhance the coherence and the efficiency of the Belgian support. Both the GESF and the Climate Change program will require distinctive but complementary expertise (e.g. expertise in green economy or renewable energy on one side, expertise in structural spatial planning and IWRM on the other side). Having both types of expertise within the same umbrella would present a number of opportunities (e.g. facilitate exchange of data, information, knowledge...).

## **2. 4. NETWORKING AND INVOLVEMENT OF OTHER DEVELOPMENT PARTNERS**

The support to the 3 selected provinces will involve academic research in the related fields and the specificities of 3 provinces will be favoured. Academic studies related to Climate Change, Integrated Water Resource Management and urban planning will be endorsed. Networking with national and international universities and research centres are considered as opportunity to:

- Facilitate exchange of information;
- Promote basic and applied research activities both at national and international levels based on the data collected within the course of the project;
- Facilitate international networking;
- Develop local knowledge and explore alternative solutions.

The TSU will play a facilitation role to enhance the collaboration of the provinces with national universities and research centres in association with renowned Vietnamese and international universities.

The TSU will also play a facilitator to prepare the ground for long-term investments in the selected provinces. This can be done by involving and communicate with potential interested development partners such as the World Bank and the Asian Development Bank.

### **3. INTERVENTION FRAMEWORK**

#### **3. 1. GENERAL OBJECTIVE**

To contribute to the sustainable development of Vietnam, by enhancing its resilience to Climate Change.

#### **3. 2. SPECIFIC OBJECTIVE**

To strengthen the capacities in climate change management in relation to Integrated Water Resource Management and Urban Development.

#### **3. 3. EXPECTED RESULTS AND ACTIVITIES**

##### **3. 3. 1 R1 Expertise is provided to the provinces of Ha Tinh, Ninh Thuan and Binh Thuan**

###### **A.01.01 Inception phase**

During 6 months the TSU will prepare the start-up phase of the 3 provincial interventions. This time should be used to:

- Recruit TSU personnel and consultants;
- Develop a strategy to support the 3 provinces according to their specific needs in an equitable way;
- Develop coordination mechanisms between the 3 provinces in a participatory way;
- Develop coordination mechanisms with the line ministries and the donors community;
- Set up the Technical Advisory Committee and define its rules and regulations;
- Guide the consultants to conduct the technical Institutional and capacity needs assessment of the main partners;
- Assist the 3 Project Coordination Units (PCU) in assuring the effective operation of the inception phase of their respective project;
- Support the 3 PCS in the redaction of the first action plans;
- Support the 3 provinces to develop the monitoring and evaluation (M&E) methodology and tools in a coordinated way;
- Guide the 3 provinces to develop a data collection strategy (protocol, tools for collection and analysis...) according to the needs of the up-coming climate change and hydraulic studies and modelling.

In parallel the BTC Representation in Hanoi will assist the 3 PCUs in:

- The preparation of Project Operation Manuals (POM) of the provinces
- The administrative and financial support



### **A.01.02 Implementation of provincial action plans**

The TSU is expected to contribute to the provincial interventions through support the following activities

- base line surveys
- preparation of action plans
- implementation of action plans
- preparation of ToR for studies
- collection of data
- analysis of data
- development of models (hydrology, climate change, ..)
- revision of Master plans
- capacity development of staff
- support to M&E

Expertise to support the provincial projects will be crucial in the first years in particular, i.e. prior to the decision of the pilot investment projects. In order to live up to these tasks, the TSU will assure that the following expertise is timely available in the provinces:

- Town planning
- Architect
- Integrated water resource management
- Water engineering
- Climate change
- Geographic Information System (GIS)
- Environment
- Hydrology
- Capacity development in the water and climate change sector
- Community development
- Communication

A major challenge for the TSU will be to share the available expertise between the 3 provinces according to the specific needs of each province in a balance way. Coordination between the action plan activities will be needed in order to guarantee the share of technical support and to avoid delays in the implementation of the activities. This effort of coordination will be ensured by the TSU during the preparation of the action plan of the 3 provinces. In case of conflict between the different agenda, a solution will be find at the level of the Steering Committee of the TSU, considering the following principles:

- Overall, the technical expertise should be equally shared between the 3 provinces, with a focus on a specific province during short periods, depending on the local needs;

- The TSU personnel will conduct regular visits in the 3 provinces (at least once a month) for overview of the activity progress of the project and general coordination. At this occasion an up-date of the schedule of the different technical experts will be possible base on the request of the province and observations;
- The expertise will be made available for specific events involving actors external to the program (Ministries, international stakeholders, universities...) having specific timing constrains;
- The expertise will focus on activities that may substantially affect the overall activity schedule of a province;
- A special attention will be given on a province that is facing important challenges (e.g. a particular technical problem, lack of comprehension/support from some actors, important delays in the implementation of the activities...).

### **3. 3. 2 R2 Coordination at central and provincial level is strengthened**

Vietnam has developed comprehensive strategies on climate change (MoNRE), on sustainable urban development (MoC) and on green growth (MPI). However, local authorities are encountering difficulties in the practical implementation of these strategies on the field, and there is a need to strengthen the feedback from the field to the ministry level on the local experiences. One of the objectives of the TSU is therefore to support both province and technical ministry levels to strengthen their links. To achieve this, the following activities will be implemented:

#### **A.02.01 Situation analysis**

- Review of role and responsibilities of national and provincial actors & development of a coordination strategy;
- Identification of existing data at central level.

#### **A.02.02. Strengthen collaboration and information mechanisms**

- Strengthen M&E of Climate Change data;
- Assure feedback of implementation of national policies;
- Review roles and responsibilities of different stakeholders;
- Collaboration with Green Economic Growth facility;
- Assure that data at national level are available at provincial level and *vice versa*;
- National and international study tours in coordination with 3 Provinces;
- Set up of a technical advisory committee;
- Coordination with other programs related to adaptation and mitigation measures with regard to climate changes.

#### **A.02.03. Networking**

- Stimulate collaboration with universities;
- Stimulate exchange with other development partners, both bilateral and multilateral.

### **3.3.3 R3 Knowledge management of the experiences is assured**

During the course of the program a large set of information and experiences should be learned. One of the purpose of the TSU will be to collect these lessons, to disseminate them and to favour their use for different purposes such as policy making, project design and academic research. The collection, analysis and diffusion of data, studies and lessons learned should therefore be useful for a large set of actors from the province authorities themselves, the line ministries, the donor community, the academic arena to the private sector and the communities. This will require the following activities:

#### **A.03.01 Capacity building in M&E**

- choice of appropriate tool
- training sessions

#### **A.03.02 Develop lessons learned**

- collection of experiences
- production of concept notes

#### **A.03.03 Dissemination of lesson learned**

- Training and experience sharing working groups of national & provincial agencies
- Organization of workshops, seminars at national level for both national and provincial agencies
- Participation in fora such as Vietnam Urban Forum (VUF)

## **3.4. INDICATORS AND MEANS OF VERIFICATION**

During the inception phase a Monitoring & Evaluation (M&E) system will be set-up in order to monitor the progress towards results (outputs and outcomes) and to assess successes and weaknesses. This M&E system will be coherent with the M&E system for the 3 Provinces. The main indicators of success of the programme in the 3 provinces will in the first place depend on whether the results of the projects in the 3 provinces are obtained. Therefore indicators for the provincial projects will also reflect on the performance of the TSU. Some of the selected indicators of the TSU should reflect how the Climate change program is supporting both national and province authorities to implement the SEDP.

Additional indicators in relation to the performance of the TSU are:

### **3.4.1 Expertise is provided to the provinces**

- Action plans of TSU are coherent with the action plans of the provincial projects;

- The expertise of the TSU identified in the consolidated six monthly provincial action plans is timely available;
- Appropriate models are developed;
- The capacity of staff of the provincial projects has reached expected standards;
- Master plans are adapted.

#### **3. 4. 2 Coordination at central and provincial level is strengthened**

- The TSU has insight and access to all relevant data existing at central level;
- The TSU assures regular feedback to all relevant ministries involved in climate change, integrated water management en city development;
- Roles and responsibilities of different stakeholders are clearly identified;
- Provinces use data from central databases;
- The central level uses data from provincial projects;
- The strategy of the programme is coherent with the Climate change, the sustainable urban planning and Green Economic Growth strategies of Vietnam;
- Development partners and academics participate in activities organised by the TSU.

#### **3. 4. 3 Knowledge management**

- Written concept notes based on experiences are available;
- The TSU is active member of relevant fora in Vietnam, such as the Urban Forum;
- Participants of workshops represent different actors involved in the program (community, private sector, district, city, province and national authorities, academia...).

The TSU indicators will be reviewed during the set-up of the M&E system.

### 3. 5. RISKS

#### Implementation risks

Risk	Risk Level	Mitigation Measure
Existing data not accurate, up-to-date and/or made available	Medium	Capacity building of the technical staff of the related departments. General agreement from all related ministries to share all the needed data at from the start of the project - Use experience from CAPAS project
Disagreement on parameters, standards, technology, methodology related to the assessments	High	Exposure to good international and national practice by the TSU and support from consultants could convince the local authorities
Chances to introduce new concepts reduced	Medium	By carefully monitoring of the project and by retaining the right of no objection at key stages in the approval process, BTC could deploy technical assistance of the TSU in a strategic manner and positively influence the project and develop appropriate E&M tool such as the MET software from CAPAS
Planning management methods are obsolete, fragmented, and inconsistent	High	Comprehensive renovation of planning management methods towards more strategic, development-oriented and spatially unified
Poor coordination between sectors, stakeholders involved and limited public participation in planning process	High	Planning and implementation have to be clear, detailed and represent the role of each sector and stakeholder involved as well as to determine the responsibility of stakeholders
Local authorities professionals, and major stakeholders have difficulties to coping with CC threats	Medium	Awareness raising on climate change impacts; adaptation, mitigation and national program on climate change. Liaise with international experiences.

### Effectiveness risks

Risk	Risk Level	Mitigation Measure
Available data are not used/made available	Medium	Involvement of 3 key ministries in coordination and steering mechanisms
The TSU does not provide timely expertise to the provinces	Medium	<ul style="list-style-type: none"> <li>- coordination of provincial steering committees and steering committee of TSU</li> <li>- coordination mechanism between provinces</li> <li>- possibility to recruit ad hoc consultants</li> </ul>
The design for pilot studies are not according to current standards and are not timely approved	Medium	close collaboration with MoC is part of the strategy of TSU
Trans sectional challenges come up that are not under the mandate of the 3 Ministries directly involved	Low	MPI has a coordinating role
Coordination among key ministries at central level is weak	Low	The key ministries are represented in the direction of the TSU

### Institutional risks

Risk	Risk Level	Mitigation Measure
Unclear distribution of tasks and responsibilities between various institutions that relate to the project	Medium	Clear mandates and division of tasks and responsibilities is expected from new decrees. Exposure to international best practice, clearer decrees may clarify the administrative organization, while training programs will strengthen the defined agencies in charge of the Program execution modalities. New Water Law should clarify responsibilities in relation to Water Resource Management and new Planning Law in relation to Bottom up planning techniques

Lack of National leadership for coordinating the project	High	TSU and MPI will have a key role in coaching the stakeholders on the importance of coordination among ministries that will have a benefit for all parties. Intensive capacity building of technical ministries will occur during the Inception Phase
--	------	--

#### **Fiduciary risks**

Risk	Risk Level	Mitigation Measure
Weak technical and financial management capacity at TSU	Low	recruitment of adequate staff in TSU
Financial procedures are not respected	Low	recruitment of adequate staff in TSU

#### **Management risks**

Risk	Risk Level	Mitigation Measure
Unclear distribution of roles and mandates	Medium	New decrees are in progress
The coordination between the TSU and the provincial project activities is lacking	Medium	commitment to organise six monthly steering committees at different levels
Direction of the TSU is not available	Medium	- mechanisms included to delegate authority - 2 full-time coordinators for the daily management

## 4. RESOURCES

### 4.1. BUDGET

The Belgian contribution amounts to 4,000,000 EUR. The detailed budget, including the disbursement chronogram, is given in Table 1.

The Vietnamese contribution amounts to 400,000 EUR and will consist of human resources of the TSU and a contribution to the coordination between central and provincial level.

In order to facilitate the start-up of the of the intervention, commitments and expenses may be made before the signature of the Implementation Agreement between Belgian Government and BTC. These shall concern logistics and human resources for a maximum amount of 114.200 EUR.

### 4.2. HUMAN RESOURCES

An overview of the long-term resources of the TSU is given in Table 1. The Belgian contribution will also be used to procure services of short-term consultants (both Vietnamese and international), such as a climate change and environment expert, a hydrology expert and an expert in capacity development in the water sector.

**Table 1:** overview of long term human resources of the TSU

Function	Time allocation	Duration (months)	Appointed by	Funded by
Vietnamese director	50%	72	MPI	VN
2 Vietnamese Vice-directors	50%	72	MoC, MoNRE	VN
National Coordinator	100%	72	MPI	BTC
Climate Change & IWRM national officer	50%	72	MoNRE	VN
Urban planning national officer	50%	72	MoC	VN
International Town-planner advisor	100%	36	BTC	BTC
International IWRM advisor	100%	36	BTC	BTC
International Water engineer advisor	100%	30	BTC	BTC



National town-planning advisor	100%	30	BTC	BTC
National IWRM advisor	100%	60	BTC	BTC
National Climate Change advisor	100%	36	BTC	BTC
National data management & GIS advisor	100%	36	BTC	BTC
National community and communication advisor	100%	36	BTC	BTC
Administration and finance officer	100%	72	BTC	BTC
Secretary/translator	100%	72	BTC	BTC
Driver	100%	72	BTC	BTC

An agreement has been made with the Water and Sanitation program (WSP) managed by the WB. WSP will support the TSU with the provision of 4 man/months of short term consultancy in the hydraulic sector. The expert will support directly the activities at province level under the TSU umbrella.

#### **4. 3. MATERIAL & EQUIPMENT**

The material and equipment procured in the framework of the project will mainly consist of office rental, office and ICT equipment and means of transport. In order to ensure a certain economy of scale, the office space and its facilities could be shared with any other donor project.

Table 2: overview of the budget in EUR

		<b>BUDGET TOTAL</b>							
			Unit	Q	Amount	BUDGET BEL	Mod.	%	BUDGET VN
<b>A</b>		<b>Available expertise</b>				<b>2,910,000</b>		<b>73%</b>	<b>172,800</b>
A	01	<i>Technical support to provincial and central levels</i>				2,910,000		73%	172,800
A	01 01	National institutional staff				180,000			172,800
		National director part-time	FR	72	700				50,400
		2 Vice directors (MPI-MoC, MoNRE)	FR	144	500				72,000
		Coordinator full-time	man/m	72	2,500	180,000			
		CC & IWRM officer (part-time) at DHMCC	FR	36	700				25,200
		Urban planning officer (part-time) at MoC	FR	36	700				25,200
A	01 02	International technical assistance				1,530,000	OM		
		Town-planner advisor (co-coordinator first 3 years)	man/m	36	15,000	540,000			
		Integrated water resource management & CC advisor	man/m	36	15,000	540,000			
		Water engineer advisor	man/m	30	15,000	450,000			
A	01 03	Vietnamese technical assistants				750,000	CM		
		Architect, town-planner	man/m	30	2,000	60,000			
		Integrated water resource management and project M&E advisor	man/m	60	2,500	150,000			
		Climate change advisor	man/m	36	2,200	79,200			
		GIS & IT advisor	man/m	36	2,200	79,200			
		Community and communication advisor	man/m	36	2,000	72,000			
		Administration and Financial Officer	man/m	72	2,000	144,000			
		Secretary/translator	man/m	72	1,800	129,600			
		Driver	man/m	72	500	36,000			
A	01 04	Vietnamese and international consultants				430,000	PM		
		Climate change and environment expert	man/m	6	20,000	120,000			
		Hydrology expert (contribution from WSP)	FR	4		0			
		Data management, IT & GIS specialist	man/m	6	20,000	120,000			
		Expert in capacity development in the water and CC sectors	man/m	5	20,000	100,000			
		Other consultancy to support the 3 provinces	lump	1	90,000	90,000			

A	01	05	Training on project management of the TSU staff	lump	1	20,000	20,000	OM		
<b>A</b>			<b>Strengthen capacities of the 3 provinces in CC, IWRM, urban planning &amp; coordination between provincial &amp; central levels</b>				<b>542,000</b>		<b>14%</b>	<b>227,200</b>
A	02		<i>R 1: Support to the 3 provinces</i>				147,000	PM	4%	
A	02	01	Flights and per diem (follow-up activities in 3 provinces)	unit	210	700	147,000			
A	03		<i>R2: Coordination at central and provincial level is strengthened</i>				295,000	PM	7%	227,200
A	03	01	Situation analysis of national and provincial actors & development of a strategy	lump	1	30,000	30,000			
A	03	02	Advisory committee	unit	10	1,500	15,000			
A	03	03	Strengthen collaboration and information mechanisms				200,000			227,200
			Training and experience sharing working groups for ministries & provinces	lump	1	50,000	50,000			50,000
			Data collection at national level	lump	1	50,000	50,000			50,000
			National and international study tours in coordination with 3 Provinces	lump	1	50,000	50,000			50,000
			Organization of workshops, seminars at national level	lump	1	50,000	50,000			77,200
A	03	04	Networking				50,000			
			Contribution to VUF	lump	1	20,000	20,000			
			Coordination with academics and institutes	lump	1	30,000	30,000			
A	04		<i>R 3: Capitalisation</i>				100,000	PM	3%	
A	04	01	Capacity building in M&E in CC with IT tool, training and consultancy	lump	1	50,000	50,000			
A	04	02	Production and dissemination of lesson learned	lump	1	50,000	50,000			
<b>X</b>			<b>Contingencies</b>				<b>114,900</b>		<b>3%</b>	
X	01		<i>Contingencies</i>				114,900			
X	01	01	Contingencies in Project Management	lump	1	34,900	34,900	PM		
X	01	02	Contingencies own management (ATI and consultancy)	lump	1	80,000	80,000	OM		
<b>Z</b>			<b>General means</b>				<b>433,100</b>		<b>11%</b>	<b>0</b>
Z	01		<i>Human resources</i>				1,500	OM	0%	
Z	01	01	Legal advice	unit	1	1500	1,500			
Z	02		<i>Investments</i>				195,400	PM	5%	
Z	02	01	Vehicles				23,000			

			Motorbikes		unit	2	1500	3000			
			Car		unit	1	20,000	20,000			
Z	02	02	Office equipment		unit	11	600	6,600			
Z	02	03	IT equipment					15,800			
			Computers		unit	6	500	3,000			
			Laptops		unit	8	600	4,800			
			Printers		unit	1	500	500			
			Copiers		unit	1	2,500	2,500			
			Other equipment (including software)		lump	1	5,000	5,000			
Z	02	04	Office rent or rehabilitation & LAN installation		lump	1	150,000	150,000			
Z	03		Operating costs					151,200	P M	4%	
Z	03	01	Utilities		month	72	300	21,600			
Z	03	02	Vehicle operating costs		month	72	500	36,000			
Z	03	03	Communications incl. internet		month	72	250	18,000			
Z	03	04	Operation costs		month	72	800	57,600			
Z	03	06	Steering Committee		unit	12	1,500	18,000			
Z	04		Audit and evaluation					85,000	O M	2%	
Z	04	01	Audit		lump	5	7,000	35,000			
Z	04	02	MTR, final evaluation in coordination with 3 CC projects		lump	2	25,000	50,000			
<b>TOTAL</b>								<b>4,000,000</b>			<b>400,000</b>
								<b>3,246,500</b>			<b>Own Management</b>
								<b>753,500</b>			<b>Project Mgmt</b>

## 5. IMPLEMENTATION MODALITIES

### 5. 1. IMPLEMENTATION AND FOLLOW-UP STRUCTURES

#### 5. 1. 1 Steering Committee

A steering committee will be created to guide the Technical Support Unit. The steering committee will consist of the following members from the national and provincial levels:

- The vice-Minister of MPI (chairman), or his delegate;
- The BTC resident representative for Vietnam (co-chairman);
- a representative of MoF;
- a representative of MoNRE;
- a representative from MoC;
- vice chairman of the people's committee of the province of Ha Tinh;
- vice chairman of the people's committee of the province of Ninh Thuan;
- vice chairman of the people's committee of the province of Binh Thuan.

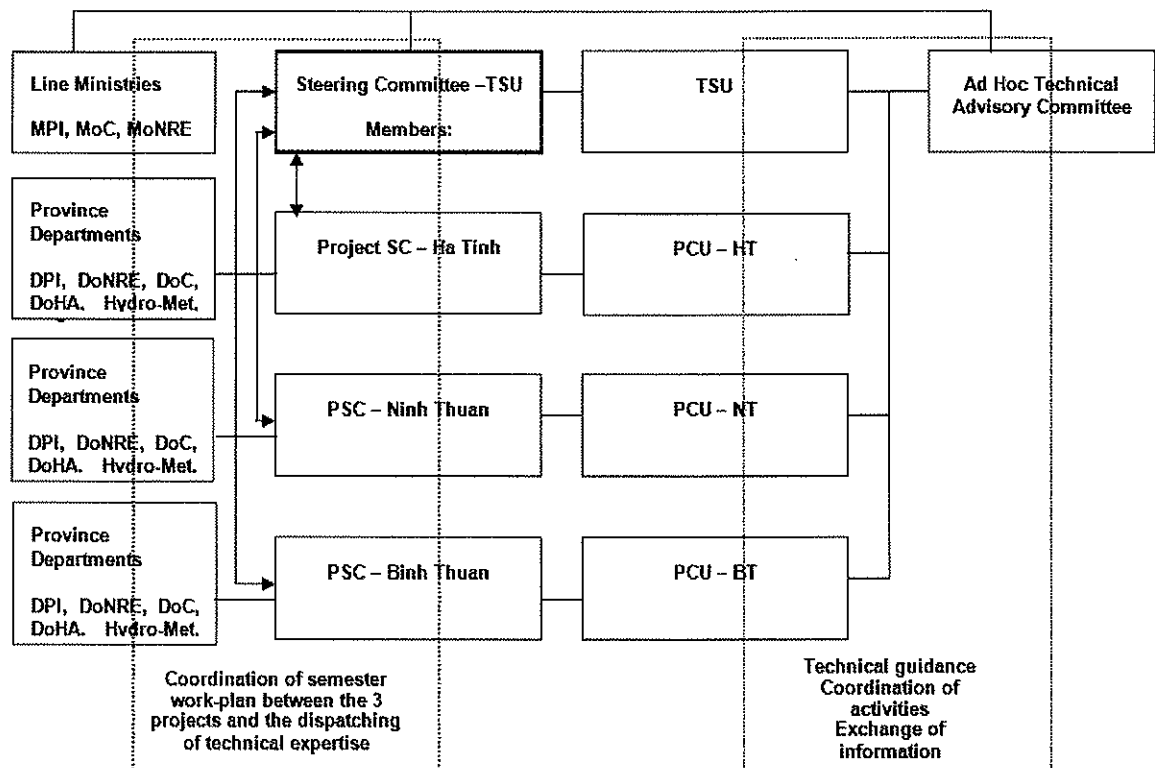

**Fig. 1:** Structure of the Climate Change program funded by Belgium and Vietnam

The steering committee lays down its own internal rules and regulations and takes decisions by consensus. The members can delegate their mandate. The steering committee can invite any relevant person to attend the meeting as an advisor. The project directors of the provincial projects will attend as observer.

The steering committee will meet on a six-monthly basis until the closure of the project, but it can also meet at the request of one of its members. It will be planned in coordination with the organization of the provincial steering committees to assure that support requested by the provinces can be provided by the TSU.

The steering committee of the TSU is in charge of the validation of the coordination of both the joint activities between the 3 provinces organised under the guidance of the TSU and the repartition of the available expertise of the TSU between the 3 projects. If the capacity of the TSU is not sufficient to deal with the various demands of the 3 provinces at the same time, a negotiation process between the 3 provinces and the TSU will be launched in order to adapt the work plan of the TSU in the best way considering the priorities. This work plan will be approved by the Steering Committee of the TSU where the 3 provinces are represented.

The Steering Committee of the TSU will ensure the overall coherence of the program as shown in Fig 1.

The steering committee will also provide general guidance to the TSU and is mandated to:

- approve the six-monthly progress and financial reports;
- approve the six-monthly action and financial plans;
- approve the implementation manual at the start of the intervention;
- endorse the recommendations of reviews;
- recommend modification of the objectives, the total budget and the duration of the project to the Vietnamese and Belgian Government;
- approve modifications to the TFF, except for modifications of the objectives, the total budget and the duration of the project;
- approve and follow up the action plan related to the closing process and the final report of the project.

### **5. 1. 2 The TSU**

The direction of the TSU will be composed of a director of MPI, a deputy director of MoC and a deputy director of MoNRE.

The daily management of the TSU will be assured by a Vietnamese and an International Coordinator. The latter will be chosen by BTC among the long term international staff. BTC will make sure that the position of the co-coordinator will be fulfilled throughout the project duration.

In addition to the activities described in chapter 3 the direction of TSU will assure:

- Drafting a project operation manual for approval by the steering committee;
- Quarterly progress and financial reports;
- Six-monthly action and financial plans;
- Tendering for the procurement of works, goods and services in conformity with applicable regulations;
- ToR for audits and provide follow-up on audit and evaluation recommendations;
- Administrative support to the steering committee (secretariat, agenda, documents, minutes; dissemination of minutes);

### **5. 1. 3 Technical Advisory Committee**

A technical advisory committee will be created to advise the provinces and the program in a larger perspective, when technical problems/challenges occur that go beyond the province capacity or on demand of the provinces. Its main objective will be to facilitate the discussions and to give technical advises when the related authorities would be confronted with different technical options and to assist them in taking the necessary steps to select the most appropriate solution.

The technical advisory committee will be chaired by the TSU director. The 2 coordinators will be permanent members of this committee as well as the directors of the 3 PCU. Other members will be chosen on an *ad hoc* basis, adapted to the different topics to be dealt with. The members will be chosen among relevant ministries, technical experts, academic staff and development partners. The detail set-up and operating modalities of the committee will be further detailed in a participatory way with the main relevant ministries (MPI, MoNRe and MoC) and the 3 provinces during the inception phase of the TSU.

## **5. 2. COORDINATION MECHANISMS**

It will be important to clearly define the tasks of the long term expertise in the six monthly TSU action plan in order to assure that TSU can respond as best as possible to the expectations of both provincial level and central level. The director of the TSU will assure that there is a consultation before the six monthly action plans of the provinces are submitted to the respective Steering Committees.

During the inception phase the TSU direction, together with the 3 PCU and the line ministries, will define in detail the coordination mechanisms to be developed between these actors.

The TSU direction will also assure that audits and monitoring & evaluations of the TSU (Mid Term Review and Final evaluation) will coincide with the similar exercises of the 3 provincial projects.

## **5. 3. MANAGEMENT MODALITIES**

### **5. 3. 1 Underlying principles**

The management modalities will follow the guidelines on management and utilisation of ODA, defined in the Vietnamese Decree 131 of 2006, or its future revisions, except for specifically defined budget lines on BTC own management.

The TSU will ensure adherence to the UN-EU (2007) guidelines, or its future revisions, for financing local costs in development cooperation in Vietnam. Deviations should be motivated and obtain approval of the steering committee.

All project activities, except for the audit and M&E will be co-managed by MPI and BTC. The director of the TSU will be authorising officer. The Resident Representative of BTC in Hanoi will be the co-authorising officer and give no-objections.

### **5. 3. 2 Human Resources**

BTC will recruit both the short-term and the long term international expertise with the consent of MPI.

The Direction of TSU will recruit the national expertise upon consent of the BTC representation and MPI.

### **5. 3. 3 Financial management**

The financial management of the project will be assured by the direction of the TSU, based upon action and financial plans previously approved by the steering committee.

### Bank accounts

Two bank accounts called "Belgian contribution TSU" shall be opened for the Belgian contribution at a commercial bank in Vietnam: a main account in EUR and a second one in VND). The main account will be replenished by BTC in quarterly instalments based on the provisions made in the approved action plans. The VND account will be replenished from the main account. They will be operating by double signature, according to the modalities defined in Table 3.

Table 3:

Signature 1	Signature 2	Limit
Vietnamese Coordinator	International Coordinator	25,000 EUR
Authorizing officer	Co-authorizing officer Resident representative	>25,000 EUR The limit depends on MPI rules and regulations BTC representation

For local expenses under BTC own management, an account shall be opened in Hanoi and managed according to BTC procedures.

### Funds transfer

The TSU direction will introduce requests for fund transfers to the BTC Resident Representative. A first instalment will be made after the opening of the TSU account. Subsequent requests will be based on action and financial plans approved by the steering committee.

The amount of the transfer equals the estimated needs of funds for the following three months increased with a margin. The transfer of funds by BTC will be conducted at the beginning of the quarter. However following prerequisites have to be met:

- The accounting for the project must be up to date and must have been transmitted to the BTC Representative;
- The financial planning of the current quarter has been transmitted to BTC Representative;
- The amount of the request does not exceed the budget balance;
- The action plan of the recommendations proposed by external audits has been reported to the BTC Representation

In addition, intermittent urgent cash calls may be submitted but must be properly motivated.

The payment of the final balance will be subordinated to the same conditions as mentioned above.

### Financial planning

Quarterly, the TSU direction will send a financial planning to the BTC Representation based upon six monthly action plans approved by the steering committee. This planning will be done in accordance with BTC procedures.

### Accounting



The accounting of the project will use BTC accounting tools and guidelines while respecting the regulations on management and utilization of ODA, defined in the Decree 131 of 2006, or its future revisions.

### **Budget management**

The TSU direction must document all budget modifications according and report them in the progress reports. Any budget change must be reported following the BTC procedures. The project coordinators will assure a strict follow-up of TSU commitments.

### **5. 3. 4 Procurement**

Procurement of goods, works and services executed in project-management will follow the Vietnamese regulations for public tendering. The TSU direction must endorse the allocation, invoices and payments of contracts in writing.

For the BTC executed budget lines, procurement will be done according to the Belgian law on public tendering.

Upon request, all members of the steering committee will have access to all administrative, financial and technical documentation regarding project procurement.

*Table 4: Procurement procedure to apply and publication requirement*

<b>Procedure</b>	<b>Publication</b>	<b>Works</b>	<b>Supplies</b>	<b>Services</b>
Direct purchase	Not mandatory	Below 5.000	Below 5.000	Below 5.000
Detailed ToR		EUR	EUR	EUR
Minimum 3 pro- forma				
Competitive negotiated procedure	Invitation to national and/or international bidders subject to the technical complexity of the assignment and the availability of the needed expertise in the country	Between 5.000 and 67.000 EUR	Between 5.000 and 67.000 EUR	Between 5.000 and 67.000 EUR
Detailed specifications				
Minimum 3 invitations				
Open procedure	Mandatory: Invitation to national and/or international bidders subject to the technical complexity of the assignment and the availability of the needed expertise in the country	Above 67.000	Above 67.000 EUR	Above 67.000
Detailed specifications		EUR	EUR	EUR

### **5. 3. 5 Monitoring & Evaluation**

An external mid-term review (MTR) will be performed after 36 months of project implementation and an End of Term Review (ETR) before the closure of the intervention.

The MTR will focus of the performance of the TSU and verify its realizations. and may propose adaptations. The MTR report will be submitted to the steering committee for endorsement of the proposed recommendations. Consequently the TSU will define an implementation plan of the recommendations in line with the decisions of the steering committee. The follow-up of this plan will be included in each progress report.

The ETR will focus on the intervention's achievements as well as on its lessons learned. This mission will perform a check of compliance with results listed in this TFF and will capitalize lessons learned.

These exercises will be conducted under the final responsibility of BTC as part of its M&E policy. To strengthen mutual accountability, coordination with similar Vietnamese procedures will be sought if possible. This will be assessed during the inception phase.

These exercises will also be coordinated between the TSU and the projects in the selected Provinces. Each project will assume its share of the costs under BTC own-management. The ToR will be drafted by the TSU with the participation of the 3 PCUs at provincial level and BTC, following BTC template and guidelines. The TSU direction will facilitate and support the missions.

Follow-up missions from BTC (internal or external personnel) will be performed during the course of the project. The TSU direction will facilitate and support of the missions needed to perform the above-mentioned exercises.

### **5. 3. 6 Financial and procurement audit**

The project accounts are subject to external audits, to assess

- whether the accounts of the project reflect reality ;
- the existence of procedures and their application by the project;
- the economic and efficient use of funds (value for money).

BTC will draft terms of references of the audits that will inform the steering committee. The external auditor, contracted by BTC has to be a certified independent company either national or international. The audit company must abide by international standards of auditing.

The TSU must be yearly audited. The audit report has to include recommendations that will be presented to the steering committee. The TSU will draft a follow-up action plan related to the recommendations of the audit and submit these to the steering committee. The steering committee can order additional audits if necessary.

Moreover,

- Check the compliance, ex-post, between payments from the specific bank account and the work realised on field and locally, with the supporting documents, kept by the partner;
- Check the respect of the management procedures of the project including management of all project assets and procedures mentioned in the POM;
- Check the respect of the public procurement Vietnamese rules and internal regulations.

### **5. 3. 7 Taxes and Duties**

Whatever taxes or duties claimed under the Vietnamese laws and regulations, will be taken in charge by the Vietnamese contribution. The Belgian contribution shall not be used to pay taxes, customs or duties for procurement of equipment, labour and services.

### **5. 3. 8 Closure of the project**

Six months before the end of the intervention, a financial report will be elaborated by the TSU direction and presented to the steering committee. BTC will launch the external final evaluation of the project at that time.

The project will be closed at the latest at the end of the validity period of the Specific Agreement (duration of the intervention + 1 year).

Beyond the validity of the Specific Agreement, no expenditure will be accepted except if related to commitments entered into force before the expiry date, endorsed by minutes of the steering committee's minutes.

#### **5.4. REPORTING**

The quality (reliability, timeliness, completeness) of the reporting will determine the future disbursements for the project.

All reports will be issued in Vietnamese and English. In case of interpretation, the English version will always prevail.

BTC may ask for additional information on the report content and/or additional documents.

##### **Progress reports**

The frequency and format of the progress reports shall comply with the harmonized reporting system agreed between GoV and the donors, in accordance with Decision 803 and use its prescriptions and templates.

During the inception phase, on the basis of the TSU and BTC proposals, the first SC will decide on the structure and all necessary templates. If necessary, the Vietnamese system will be completed to guarantee that the reports will include the following requirements:

- Overview of activities executed and results achieved: *this part will identify the difference between what has been planned (on an operational and financial ground) with what has been implemented:*
  - o follow-up of the implementation of the planning with a list of the activities implemented;
  - o follow-up of the procurement plan;
  - o if useful, narrative of the activities;
  - o list of incomes and expenses of the previous quarter;
  - o budget follow up;
  - o cash flow reports (bank account statements and cash reconciliation).
- Analysis of the implementation: *this part will identify the reasons for not respecting the planning, clear action plan with corrective measures, responsible and deadlines.*
  - o identification and description of successes;
  - o identification and description of problems;
  - o a narrative highlighting the discrepancies with the previous periods;
  - o identification and description of risks.
- Activity and financial planning update:
  - o update of the planning taking into account the analysis of successes, problems and risks;
  - o update of the procurement planning;
  - o The three-monthly budgeted Action Plans and list of main engagements;
  - o The related cash forecast.

##### **Specific information for the SC meetings**

The following documents will be presented to the SC:

- (i) The progress reports of the implementation period since the former SC
- (ii) action plans for the following 6 months (compiling information regarding operations, procurement and financial planning)
- (iii) strategic recommendations and / or decisions to be endorsed by the SC

### Annual report

The TSU direction will present annually a result-oriented consolidated report on progress towards results (output and outcome) and concisely assess progress, suggest recommendations to the Steering Committee and highlight lessons learned.

The standards set in the BTC M&E Policy must be respected. The timing will respect the Belgian and the Vietnamese requirements.

**Table 6:** Reporting Summary

Reports	Responsible	Content	Destination
Quarterly progress report and operational planning	TSU direction	Progress reporting and planning (activities, finance, tenders, ...)	MPI BTC representation
6-monthly progress report and action plan Prior to a Steering Committee meeting	TSU direction	Progress reporting and activity and financial planning	Steering committee
Annual Report	TSU direction	Annual progress report (results, activities, budget)	Steering committee
External audit reports	Auditing firm	Financial audit + value for money	Steering committee Belgian cooperation
MTR Report	External consultant	External Mid term review	Steering committee
Final Evaluation Report	External consultant	Final Evaluation	Steering committee
Final Report	TSU direction	Provisional acceptance of program activities	Steering committee

## 6. CROSS CUTTING THEMES

### 6.1. ENVIRONMENT

The objectives and results of the programme are linked to environmental preoccupations and as such could be considered as an environmental project (cfr. DAC code 41010). Therefore environment is to be considered both as a sector perspective and as a cross-cutting theme. A special point of attention will be to retain that adapting to climate change, and promoting sustainable urbanisation and water management, relies on sound environmental practices and following principles such as the wise-use of resources, energy saving, clean mobility and technology, etc...

Since water is essential for socio-economic development and for maintaining healthy ecosystems, properly managed water resources are a critical component of growth and poverty reduction and equity. The livelihoods of the poorest are typically associated with access to water services.

With higher urbanisation rates, increasing demand for drinking water will put stress on existing water sources. Energy demand will more than double in poor and emerging economies in the next 25 years and hydropower will need to be a key contributor to clean energy production. Floods and droughts will continue to threaten farmer livelihoods and lowland economies. Besides the needs for these human activities we have to ensure that the environmental water flows required to maintain ecosystems are also maintained.

Water resource management aims at optimising the available natural water flows, including surface water and groundwater, to satisfy these competing needs. Adding uncertainty, climate change will increase the complexity of managing water resources. Prevention and management of floods will also be at the heart of the programme's strategy.

The ten steps project's strategy aims at promoting both mitigation and adaptation strategies which will include elements such as:

- Urban planning that considers climate change
- Energy efficient housing
- Low carbon transport
- Sustainable water management
- Floods prevention & warning
- Institutional strengthening & capacity building
- Pilot projects experimentation such as mangrove preservation
- Studies, surveys and research

Institutional strengthening and capacity building will be crucial components of the project. Specific attention will be given, through the training sessions, workshops, conferences or studies organised within the project to sustainable development and environmental management issues in order to provide

authorities, public bodies, civil society and private stakeholders with a common "green culture" adapted to the local context specificities and potential. This "green culture" will need to address water management challenges:

- Associated with food security and developing water-smart agricultural plans;
- Associated with rapid urbanisation;
- Developing hydropower schemes integrated with other water uses (e.g. irrigation and flood control);
- Functional early warning systems, infrastructure and institutional arrangements for coordinated action to address increased variability and changes to runoff and flooding patterns;
- Strengthening institutions for effective river basin management; and,
- Increasing the efficiency of water use.

## 6. 2. GENDER

Gender equality is critical to the outcome and impact of development interventions and central to improving development effectiveness. A strategy that considers the integration of crosscutting issues in decision-making, from planning till evaluation and feedback for new decision-making processes, taking into account the effects and impacts of these decisions on gender, is commonly called "gender mainstreaming".

Since women's economic and social rights are related to these gender differences and because women impact their direct environment through empowerment, the present programme addresses women not only as possible victims of climate changes, but also as agents of change in contributing to mitigation and adaptation measures, and more precisely in contributing to the development of the integrated water management. Therefore different gender mainstreaming initiatives are developed within the course of the project, being directly integrated as a component of the different activities. Furthermore gender sensitive indicators will be developed in the framework of this project.

The context of climate change makes women more vulnerable than men. Women's lack of capital, market access, knowledge, skills and decision-making powers, render them as a group, generally neglected by climate financing mechanisms. Where gender considerations are included, it is largely on an *ad hoc* basis. In order to avoid missed opportunities and to address differential impacts of climate change from the beginning of the implementation the programme 'Support to integrated water management' addresses gender in a cross-cutting way through all phases of the project cycle.

# 7. ANNEXES

## 7.1. PLANNING TSU

Available expertise	TSU PLANNING																		
	Y1			Y2			Y3			Y4			Y5			Y6			
	1	2	3	1	2	3	1	2	3	1	2	3	1	2	3	1	2	3	
Technical support to provincial and central levels																			
National institutional staff																			
National Director part-time																			
Coordinator full-time																			
MoC lab on officer (part-time)																			
MoNRE - CC lab on officer (part-time)																			
International technical assistance																			
Town-planner's specialist (first part of the project)																			
Integrated water resource management expert (recruitment prior to the start of the studies)																			
Water engineer part-time (recruitment after study phase)																			
Water resource technical assistants																			
Architect, town-planner																			
Integrated water resource management and project M&E expert																			
Climate change specialist																			
GIS & IT specialist																			
Community and communication specialist																			
Administration and Financial Officer																			
Internal controller																			
Secretary/translator																			
Driver																			
Weather and internet consultant																			
Climate change and environment expert																			
Hydrology expert (contribution from WSP)																			
Data management, IT & GIS specialist																			
Expert in capacity development in the water sector																			
Other consultancy to support the 3 provinces																			
Training on project management for the TSU staff																			
Technical support to the 3 provinces																			
Flights and per diem follow-up activities in 3 provinces																			
IR1: Coordination at central and provincial levels is strengthened																			
Situation analysis																			
Coordination among ministries on CC issues																			
Strengthen collaboration and information mechanisms																			
Training and experience sharing working groups																			
Data collection at national level																			
National and international study tours in coordination with 3 Provinces																			
Organization of workshops, seminars																			
Networking																			
IR 3: Capitalisation																			
Capacity building in M&E in CC																			
Production and dissemination of lessons learned																			

<b>BUDGET TOTAL</b>	<b>BUDGET BEL</b>	<b>Year 1</b>	<b>Year 2</b>	<b>Year 3</b>	<b>Year 4</b>	<b>Year 5</b>	<b>Year 6</b>
Available expertise	2,851,600	554,800	698,800	702,800	344,400	302,400	248,400
<i>Technical support to provincial and central levels</i>	2,851,600	554,800	698,800	702,800	344,400	302,400	248,400
National institutional staff	180,000	0	0	0	0	0	0
International technical assistance	1,530,000						
Vietnamese technical assistants	681,600						
Vietnamese and international consultants	440,000						
Training on project management of the TSU staff	20,000	20,000					
<b>Strengthen capacities of the 3 provinces in CC, IWRM, urban planning and the coordination between provincial and central levels</b>	<b>573,000</b>	<b>162,000</b>	<b>205,000</b>	<b>100,000</b>	<b>52,000</b>	<b>17,000</b>	<b>37,000</b>
<i>R 1. Support to the 3 provinces</i>	<i>168,000</i>	<i>42,000</i>	<i>42,000</i>	<i>42,000</i>	<i>14,000</i>	<i>14,000</i>	<i>14,000</i>
Flights and per diem (follow-up activities in 3 provinces)	168,000	42,000	42,000	42,000	14,000	14,000	14,000
<i>R2: Coordination at central and provincial levels strengthened</i>	<i>305,000</i>	<i>95,000</i>	<i>138,000</i>	<i>58,000</i>	<i>8,000</i>	<i>3,000</i>	<i>3,000</i>
Situation analysis of national and provincial actors & development of a strategy	30,000	30,000					
Advisory committee	15,000		3,000	3,000	3,000	3,000	3,000
Strengthen collaboration and information mechanisms	200,000						
Networking	60,000						
<i>R 3. Capitalisation</i>	<i>100,000</i>	<i>25,000</i>	<i>25,000</i>	<i>0</i>	<i>30,000</i>	<i>0</i>	<i>20,000</i>
Capacity building in M&E in CC with IT tool, training and consultancy	50,000	25,000	25,000				
Production and dissemination of lesson learned	50,000				30,000		20,000
<b>Contingencies</b>	<b>132,300</b>			<b>65,000</b>	<b>20,000</b>		<b>47,300</b>
<i>Contingencies</i>	<i>132,300</i>	<i>0</i>	<i>0</i>	<i>65,000</i>	<i>20,000</i>	<i>0</i>	<i>47,300</i>
Contingencies in Project Management	42,300			25,000			17,300
Contingencies in own management (ATI and consultancy)	90,000			40,000	20,000		30,000
<b>General means</b>	<b>443,100</b>	<b>102,600</b>	<b>58,700</b>	<b>87,200</b>	<b>57,200</b>	<b>60,200</b>	<b>77,200</b>
<i>Human resources</i>	<i>1,500</i>	<i>3,000</i>	<i>3,000</i>	<i>1,500</i>	<i>0</i>	<i>0</i>	<i>0</i>
Legal advice	1,500	3,000	3,000	1,500			



<i>Investments</i>	205,400	80,400	25,000	25,000	25,000	25,000	25,000	25,000
Vehicles	23,000	23,000						25,000
Office equipment	6,600	6,600						
IT equipment	25,800	25,800						
Office rent or rehabilitation & LAN installation (costs to be shared with GESF)	150,000	25,000	25,000	25,000	25,000	25,000	25,000	25,000
<i>Operating costs</i>	151,200	22,200	25,200	25,200	25,200	28,200	25,200	25,200
Utilities	21,600	3,600	3,600	3,600	3,600	3,600	3,600	3,600
Vehicle operating costs	36,000	3,000	6,000	6,000	6,000	9,000	9,000	6,000
Communications incl. internet	18,000	3,000	3,000	3,000	3,000	3,000	3,000	3,000
Operation costs	57,600	9,600	9,600	9,600	9,600	9,600	9,600	9,600
Steering Committee	18,000	3,000	3,000	3,000	3,000	3,000	3,000	3,000
<i>Audit and evaluation</i>	85,000	7,000	7,000	30,000	7,000	7,000	7,000	27,000
Audit	35,000		7,000	7,000	7,000	7,000	7,000	7,000
MTR, final evaluation in coordination with 3 CC projects	50,000			30,000				20,000
	<b>4,000,000</b>	<b>819,400</b>	<b>962,500</b>	<b>955,000</b>	<b>473,600</b>	<b>379,600</b>	<b>409,900</b>	

## **7. 2. TOR LONG-TERM PERSONNEL**

### **7. 2. 1 Vietnamese Coordinator**

Duty station: Hanoi city with frequent travels to Ha Tinh, Binh Thuan and Ninh Thuan provinces – Vietnam

Duration of the assignment: 75 months

Recruited by MPI

#### **Tasks**

The Vietnamese Coordinator will function on a full-time basis as the daily leader of the Technical Support Unit (TSU) during the life of the Project. S/he will ensure, under the responsibility of the TSU Director, that the tasks of the TSU, as described in the TFF, are carried out smoothly and in a timely manner.

In particular the VC will work in close coordination with the International Coordinator (Co-coordinator) and will refer to the Project Director and ensure that the members of the Steering Committee (SC) are well informed of project progress and are adequately supplied with sufficient information to carry out their decision-making responsibilities. The Vietnamese Coordinator will feed back to the TSU any changes in policy or direction that the Steering Committee may wish to carry out within the Project framework.

Reporting to the project Director the VC shall:

- Provide overall leadership of the TSU and coordinate the operations of the project activities with the related ministries and the Project Coordination Units (PCU) of the 3 target provinces (Ha Thin, Ninh Thuan and Binh Thuan) as to ensure the coherence of the program;
- Cooperate closely with the co-coordinator, in developing plans for utilisation of expertise and follow-up;
- Supervise the development of Strategic and Plans of Operation and Budgets of the program and TSU project components;
- Develop work plans and budgets for project management;
- Ensure that coordination mechanisms among ministries and with the 3 target provinces are approved and applied by the relevant authorities;
- Supervise the preparation of quarterly and annual progress reports;
- Supervise the monitoring and evaluation of the project implementation;
- Analyse and consolidate monitoring reports and prepare recommendations to the SC;
- Organise Steering Committee meetings twice a year;

- Prepare with the co-leader the contents and agenda of the Steering Committee meetings;
- Act on behalf of the Chairman of the Steering Committee when authorised, and report back to the Chairperson on actions taken;
- Ensure that all the activities foreseen during the inception phase in the 3 provinces are timely organised in a coordinated way between the 3 provinces, with a particular attention to the writing of the Project Organization Manual (POM), the baseline surveys and the monitoring and evaluation tool;
- Ensure the capturing and integration of lessons learnt and experience drawn in the implementation of project activities under the components, with a focus on the urban development issues;
- Together with the co-coordinator, recruit for the project international and national consultants according to proper terms of references;
- Together with the co-coordinator, when required, enter into employment contracts and commercial contracts for fulfilling the task of the TSU for consultancy and or training providers;
- Implement other duties as assigned by the Steering Committee Chairperson and/or BTC;
- Facilitate efforts of the TSU to coordinate activities with the 3 provinces of the Climate Change program and ensure exchange of experiences between the 3 projects;
- In coordination with the co--coordinator arrange regular TSU meetings normally on a monthly basis or more frequently if deemed necessary;
- Be proactive in securing alignment with both central and province authorities and institutions, in particular MPI, MONRE, MoC, MOHA, BTC and other related donor funded projects;
- Guarantee the setting up of appropriate coordination mechanisms among national and provincial agencies in charge of climate change and urban development;
- Guarantee the project focus on the cross cutting issues, especially environmental protection, throughout its implementation and activities;
- Organise national and/or regional workshops to stimulate coordination between central and provincial levels and to provide feedback on the different studies and gather reflections and input from Vietnamese and International partners;
- Carry other tasks as requested by the Steering Committee for the success and benefits of the Program.

## **Reporting**

The Vietnamese Coordinator shall discuss and agree with the PD, the co-leader and the Chairperson of the Steering Committee on the form and frequency of reporting. Besides periodic progress and financial reports the VC shall provide the following reports:

- An Inception Report six months after commencement of the Project including assessments on the effectiveness of the TSU operations and, if needed, proposing options for improving the structures, systems and procedures;
- Consolidated and coordinated quarterly and annual progress reports including recommendations with justification for improving the effectiveness of the project activities;
- Financial reports in accordance with the requirements of BTC and the Provincial authorities;
- Final report summarising the results of the Project including lessons learnt, conclusions and recommendation on how the achievements of the program can be sustained;
- Any other reports as requested by the Chairperson of the Steering Committee or BTC.

## **Qualifications**

The Vietnamese Coordinator shall be a senior officer of the Office of MPI, retired or in function, preferably with a project management experience, and technical or human resources development background, including good communication and coordination skills, English language knowledge, computer use being considered essential. Knowledge and experience of ODA donor procurement, safeguards and project accounting mechanisms is preferred.

### **7. 2. 2 International Town Planner advisor (co-coordinator for first phase)**

Duty station: Hanoi city with frequent travels to Ha Tinh, Binh Thuan and Ninh Thuan provinces – Vietnam

Duration of the assignment: 36 months

Recruited by BTC

#### **Tasks**

The International town-planner advisor (ITA) will function on a full-time basis as the co-coordinator of the Technical Support Unit (TSU) during the 3 first years of the Project and as technical advisor in town-planning. S/he will ensure that the tasks of the TSU, as described in the TFF, are carried out smoothly and in a timely manner.

In particular the ITA will work in close coordination with the project Vietnamese Coordinator and ensure that its members are well informed of project progress and are adequately supplied with sufficient information to carry out their decision-making responsibilities.

Reporting to the BTC representation the ITA shall:

- Provide overall leadership of the TSU and coordinate the operations of the project activities with the Project Coordination Units (PCU) of the 3 target provinces (Ha Tinh, Ninh Thuan and Binh Thuan);
- Ensure with the Vietnamese Coordinator the overall coordination of the climate change program;
- Cooperate closely with the Vietnamese Coordinator, the other International Technical Advisors, the National expertise and the consultants of the TSU in developing plans for expertise utilisation and supervise and facilitate the work of the TSU staff;
- Supervise, together with the Vietnamese Coordinator, the development of Strategic and Plans of Operation and Budgets of the project components;
- Assist the development of work plans and budgets for project management;
- Supervise the preparation of quarterly and annual progress reports;
- Supervise the monitoring and evaluation of the project implementation;
- Analyse and consolidate monitoring reports and prepare recommendations for the Steering Committee;
- Co-organise Steering Committee meetings;
- Prepare with the VC the contents and agenda of Steering Committee meetings;

- Act on behalf of the Chairman of the Steering Committee when authorised, and report back to the Chairperson on actions taken;
- Together with the Vietnamese Coordinator, recruit international and national consultants for the project according to proper terms of references;
- Jointly with the Vietnamese Coordinator, prepare contracts for consultancies and/or training providers;
- Be authorised account-holder for the accounts related to Financial Cooperation;
- Implement other duties as assigned by the TSU direction and/or BTC;
- In coordination with the Vietnamese Coordinator, arrange regular TSU meetings normally on a monthly basis or more frequently if deemed necessary;
- Be proactive in securing alignment with both central and province authorities and institutions, in particular MPI, MONRE, MoC, BTC and other related donor funded projects;
- Facilitate efforts of the TSU to coordinate activities with the 3 provinces of the Climate Change program and ensure exchange of experiences between the 3 provincial projects;
- Facilitate cooperation between the 3 provinces and the academic and research centres for developing study synergies;
- Facilitate the relationship between the 3 provinces and the donors community to look for complementary funding;
- Favour communication and cooperation between the 3 provinces, and both the related ministries and the donors' community (peer review, lessons learned, policy dialogue...);
- Facilitate the setting up of appropriate coordination mechanisms among national and provincial agencies in charge of climate change and urban development;
- Guarantee the project focus on the cross cutting issues, especially environmental protection, throughout its implementation and activities;
- Collect and analyse possible urban strategic plans and policies designed at regional or provincial levels in Vietnam or in nearby or similar countries and which could be used for reference and lessons learned;
- Propose comprehensive and realistic adaptations and mitigation measures related to water management and urban development to be applied in the three provinces with priorities;
- Develop in a participatory way a comprehensive and detailed strategy to guide the spatial planning process within the three provinces in order to integrate the Climate

Change issue;

- Support the procurement for the program goods, works and consultants with the Project Director, the Vietnamese Coordinator and the provincial Project directors, following the implementation modalities as indicated and agreed in the Program Technical and Financial Files (TFF);
- Support and contribute to the capacity development activities at both national and provincial levels related to urban development, especially in the fields of strategic structural planning, adaptation of settlements to climate change, sustainable planning, energy and water efficient buildings... ;
- Guide the process defining the framework to develop a participatory approach at province level aiming at elaborating the structural strategic plan for the 3 provinces;
- Provide technical advisory support and guidance to the relate ministries, PCU, province departments, and consultants in charge of the revision of the master plans on all aspects of urban development, urban planning, energy efficient buildings, participatory planning;
- Supervise the energy efficient and sustainable planning components of the design and implementation of the public awareness campaigns;
- Upon requests from the BTC representation, provide motivated technical non objections on terms of references, contracts, feasibility studies, master plans, priority action plans, projects detail design...;
- Ensure the capturing and integration of lessons learnt and experience drawn in the implementation of project activities under the components, including through the writing of concept notes;
- Support the organisation of national and/or regional workshops to stimulate coordination between central and provincial levels and to provide feedback on the different studies and gather reflections and input from Vietnamese and International partners;
- Carry other tasks as requested by the Program Steering Committee for the success and benefits of the Program.

## **Reporting**

The ITA shall discuss and agree with the TSU direction, the Vietnamese Coordinator and the Chairperson of the Steering Committee on the form and frequency of reporting. Besides periodic progress and financial reports the ITA shall contribute to the following reports:

- An Inception Report six months after commencement of the Project including assessments on the effectiveness of the TSU operations and, if needed, proposing options for improving the structures, systems and procedures;
- Consolidated and coordinated quarterly and annual progress reports including recommendations with justification for improving the effectiveness of the project activities;
- Financial reports in accordance with the requirements of BTC and the Provincial authorities;
- Final report summarising the results of the Project including lessons learnt, conclusions and recommendation on how the achievements can be sustained;
- Any other reports as requested by the Chairperson of the Steering Committee or BTC.

## **Qualifications**

- University degree and MSc in Urban Planning;
- Familiar with strategic structural planning, sustainable urban development, participatory planning and climate change issues;
- 10 years of experience in urban development and spatial planning with at least 5 years of experience in developing countries;
- Experience as coordinator of development projects;
- Familiar with capacity building and institutional strengthening aspects at the level of local government;
- Familiarity with the Vietnamese context is an asset;
- Proven capacities to work in intercultural team;
- Good communication and analytical skills;
- Fluency in spoken English excellent writing skills in English;
- Understanding Belgium Cooperation procedures is an advantage.



### **7. 2. 3 International Integrated Water Resources Management and Climate Change advisor**

Duty station: Hanoi city with frequent travels to Ha Tinh, Binh Thuan and Ninh Thuan provinces – Vietnam

Duration of the assignment: 36 months, 9 months after the start of the project

Recruited by BTC

#### **Tasks**

The International Integrated Water Resources Management and Climate Change advisor (IWRMA) will function on a full-time basis as technical advisor. H/she will be recruited at the start of the study phase of the 3 provinces projects (9 months after the start of the TSU).

The IWRMA will work in close coordination with the project Vietnamese Coordinator and the co-leader of the project (international technical advisor, town-planner). Reporting to the BTC representation the IWRMA shall:

- Supervise the design and establishment of the WR and climate change database;
- Support the development the IWRM concept and facilitate the creation of the institutional set-up;
- Collect and analyse possible river contracts, IWRM and climate change policies in Vietnam or in nearby or similar countries and which could be used for reference and lessons learned;
- Support the development of a comprehensive and detailed strategy to collect and analyse meteorological, climatic and water management data to guide the spatial planning process within the three provinces;
- Identify and advise on adapted methodologies and technologies which could be used in Vietnam, and in the 3 provinces in particular to assess possible impacts of climate change;
- Propose comprehensive and realistic adaptations and mitigation measures related to water management and urban development to be applied in the three provinces with priorities;
- Facilitate and supervise the hydraulic and climate change studies and modelling;
- Supervise the climate change and water components of the design and implementation of the public awareness campaigns;
- Supervise and contribute to the design and implementation of the training program related to IWRM and climate change;

- Support the procurement for the program goods, works and consultants with the Project Director, the Vietnamese Coordinator the co-leader and the provincial Project directors, following the implementation modalities as indicated and agreed in the Program Technical and Financial File (TFF);
- Review the tender documents related to IWRM and climate change transferred and provide a non-objection;
- Provide technical advisory support and guidance to the relate ministries, PCU, province departments, and consultants in charge of the hydraulic, climate change studies and modelling on all aspects of ground and surface water resources management, including Integrated Water Resource Management, and climate change;
- Support and contribute to the capacity development activities at both national and provincial levels related to environment protection, environment and climate change awareness raising, IWRM and climate change;
- Initiate coordination and exchange of information between the different ministries and the donors' community;
- Ensure the capturing and integration of lessons learnt and experience drawn in the implementation of project activities under the components, including through the writing of concept notes;
- Support the organisation of national and/or regional workshops to stimulate coordination between central and provincial levels and to provide feedback on the different studies and gather reflections and input from Vietnamese and International partners;
- Carry other tasks as requested by the Program Steering Committee for the success and benefits of the Program.

### **Reporting**

Besides periodic progress and financial reports the IWRMA shall contribute to the following reports:

- Consolidated and coordinated quarterly and annual progress reports including recommendations with justification for improving the effectiveness of the project activities;
- Financial reports in accordance with the requirements of BTC and the Provincial authorities;
- Final report summarising the results of the Project including lessons learnt, conclusions

and recommendation on how the achievements of the Project can be sustained;

- Any other reports as requested by the Chairperson of the SC or BTC.

### **Qualifications**

- MSc or higher educational degree in water resource related engineering, with post-graduate management training;
- 10 years working experiences in Water Resources Management with at least 5 years of experience in developing countries;
- Proven experience with organization/institutional development projects;
- Experience in climate change related issues;
- Familiarity with the Vietnamese context is an asset;
- Proven capacities to work in intercultural team;
- Good communication and analytical skills;
- Fluency in spoken English excellent writing skills in English;
- Understanding Belgium Cooperation procedures is an advantage.

#### **7. 2. 4 Water engineer advisor**

Duty station: Hanoi city with frequent travels to Ha Tinh, Binh Thuan and Ninh Thuan provinces – Vietnam

Duration of the assignment: 30 months, 45 months after the start of the project

Recruited by BTC

#### **Tasks**

The International Water engineer Advisor (IWEA) will function on a full-time basis as technical advisor and will take the responsibility of project co-leader for the last phase of the project. H/she will be recruited for the implementation phase of the investment projects of the 3 provinces projects.

The IWEA will work in close coordination with the project Vietnamese Coordinator. Reporting to the BTC representation the IWEA shall:

- Provide overall leadership of the TSU and coordinate the operations of the project activities with the Project Coordination Units of the 3 target provinces (Ha Thin, Ninh Thuan and Binh Thuan);
- Cooperate closely with the Vietnamese Coordinator, the other International experts, the National experts and the consultants of the TSU in developing plans for TA utilisation and supervise and facilitate the work of the TA staff;
- Supervise, together with the Vietnamese Coordinator, the development of Strategic and Annual Plans of Operation and Budgets of the Project components;
- Assist the development of work plans and budgets for Project Management;
- Supervise the preparation of quarterly and annual progress reports;
- Supervise the monitoring and evaluation of the Project implementation;
- Analyse and consolidate monitoring reports and prepare recommendations to the SC;
- Co-organise bi-annual SC meetings;
- Prepare with the Vietnamese Coordinator the contents and agenda of the SC meetings;
- Act on behalf of the Chairman of the SC when authorised, and report back to the Chairperson on actions taken;
- Together with the Vietnamese Coordinator, recruit international and national consultants according to proper terms of references;
- When required, together with the VC, enter into employment contracts and commercial contracts for fulfilling the task of the TSU for consultancy and or training providers;

- Be authorised account-holders for the accounts related to Financial Cooperation;
- Implement other duties as assigned by the project director, the SC Chairperson and or BTC;
- In coordination with the Vietnamese Coordinator, arrange regular TSU meetings normally on a monthly basis or more frequently if deemed necessary;
- Be proactive in securing alignment with both central and province authorities and institutions, in particular MPI, MONRE, MoC, BTC and other related donor funded projects;
- Facilitate efforts of the TSU to coordinate activities with the 3 provinces of the Climate Change program and ensure exchange of experiences;
- Guarantee the setting up of appropriate coordination mechanisms among national and provincial agencies in charge of climate change and urban development;
- Guarantee the project focus on the cross cutting issues, especially environmental protection, throughout its implementation and activities;
- Support the procurement for the program goods, works and consultants with the Project Director, the Vietnamese Coordinator, and the provincial Project directors, following the implementation modalities as indicated and agreed in the Program Technical and Financial File (TFF);
- Supervise the procedure of the design and the implementation stage of the investment projects in the 3 provinces;
- Review the tender documents related to pilot project investments transferred and provide a non-objection;
- Provide technical advisory support and guidance to the relate ministries, PCU, province departments, and consultants in charge of infrastructure investments;
- Ensure on-the-job training to the PCUs and the related province departments for the design control and civil work site supervision of the investment projects;
- Support and contribute to the capacity development activities at both national and provincial levels related to environment protection, environment and CC awareness raising, IWRM, infrastructure investments;
- Initiate coordination and exchange of information between the different ministries and the donors' community;
- Ensure the capturing and integration of lessons learnt and experience drawn in the implementation of project activities under the components, including through the writing of concept notes;

- Carry other tasks as requested by the Program Steering Committee for the success and benefits of the Program.

### **Reporting**

Besides periodic progress and financial reports the IWEA shall contribute to the following reports:

- Consolidated and coordinated quarterly and annual progress reports including recommendations with justification for improving the effectiveness of the project activities;
- Financial reports in accordance with the requirements of BTC and the Provincial authorities;
- Final report summarising the results of the Project including lessons learnt, conclusions and recommendation on how the achievements of the Project can be sustained;
- Any other reports as requested by the Chairperson of the Steering Committee or BTC.

### **Qualifications**

- MSc or higher educational degree in water resource related engineering, with post-graduate management training;
- 10 years working experiences in water engineering with at least 5 years of experience in developing countries;
- Proven experience with organization/institutional development projects;
- Experience in infrastructure construction supervision;
- Experience as coordinator of development projects;
- Familiarity with the Vietnamese context is an asset;
- Proven capacities to work in intercultural team;
- Good communication and analytical skills;
- Fluency in spoken English excellent writing skills in English;
- Understanding Belgium Cooperation procedures is an advantage.

## **7. 2. 5 National Climate Change advisor**

Duty station: Hanoi city with frequent travels to Ha Tinh, Binh Thuan and Ninh Thuan provinces – Vietnam

Duration of the assignment: 36 months, at the start of the study phase of the project

Recruited by BTC

### **Tasks**

The National climate Change advisor (NCCA) will function on a full-time basis as technical advisor. H/she will be recruited at the start of the study phase of the 3 provinces projects. The NCCA will work in close coordination with the project Vietnamese Coordinator and the project co-leader (international advisor). Reporting to the TSU direction the NCCA shall:

- Support the 3 provinces to gather and analyse data on projected climate change impacts and design hazard maps in the selected locations;
- Identify and advise on adapted methodologies and technologies which could be used in Vietnam, and in the 3 provinces in particular, to assess possible impacts of climate change;
- Collect and analyse possible climate change strategic plans and policies designed at regional or provincial levels in Vietnam or in nearby or similar countries and which could be used to draft adapted documents for the program;
- Support the development of a comprehensive and detailed strategy to collect and analyse meteorological, climatic and water management data to guide the spatial planning process within the three provinces;
- Based on an in-depth assessment, support the development of a comprehensive training programme on climate change for the three provinces;
- Give advice on the ways meteorological data and climate change modelling should influence the urban planning and water management processes within the three provinces;
- Propose comprehensive and realistic adaptations and mitigation measures related to water management and urbanisation to be applied in the three provinces with priorities;
- Identify the relevant legal and strategic framework related to climate change, provide a critical analysis of this framework and identify possible gaps;
- Assist local authorities and PCUs, in writing appropriate terms of references related to his/her field of expertise;

- Translate in concrete terms how the climate change issues should be communicated to public authorities, the private sector and the local communities and elaborate an action plan to be implemented by the programme;
- Support the organisation of national and/or regional workshop(s) to provide feedback on the study and gather reflections and input from Vietnamese and International partners;
- Contribute to the writing of different reports and concept notes;
- Any other reports as requested by the Chairperson of the SC or BTC.

#### **Qualifications**

- University degree in environmental sciences, climate science, or other related field;
- Proven expertise in the field of climate change and environment applied to development issues;
- At least 10 years of relevant experience in climatology in relation with territorial planning;
- Professional experience in international cooperation projects;
- Expertise in writing mission reports and other types of publications, proven writing skills in English;
- Good knowledge of development projects formulation, evaluation and/or implementation;
- Ability to communicate; and,
- Ability to work in team.



### **7. 2. 6 National data management and GIS advisor**

Duty station: Hanoi city with frequent travels to Ha Tinh, Binh Thuan and Ninh Thuan provinces – Vietnam

Duration of the assignment: 36 months, at the start of the study phase of the project

Recruited by BTC

#### **Tasks**

The National data management and GIS advisor (NDMGA) will function on a full-time basis as technical advisor. H/she will be recruited at the start of the study phase of the 3 provinces projects. The NDMGA will work in close coordination with the project Vietnamese Coordinator and the project co-leader (international advisor). Reporting to the TSU direction the NDMGA shall:

- Support the development a comprehensive and detailed strategy to collect and analyse meteorological, climatic and water management data to guide the spatial planning process within the three provinces;
- Identify the relevant legal and strategic framework related to data management, provide a critical analysis of this framework and identify possible gaps;
- Assist the 3 provinces to collect, structure and analyse the require data and to set-up a comprehensive climate change and IWRM database and an interactive WRIS;
- Identify and advise on adapted methodology and technology to manage the database;
- Collect and analyse possible database models and policies designed at regional or provincial levels in Vietnam or in nearby or similar countries and which could be used to draft the adapted strategy in database collection and management;
- Assist local authorities and PCUs, in writing appropriate terms of references related to his/her field of expertise;
- Based on an in-depth assessment, support the development of a comprehensive training programme on data management for the three provinces;
- Give advice on the ways meteorological data and climate change modelling should influence the urban planning and water management processes within the three provinces;
- Assist local authorities in the set-up and the management of their database;
- Support the organisation of national and/or regional workshop(s) to provide feedback on the study and gather reflections and input from Vietnamese and International partners;

- Contribute to the writing of different reports and concept notes;
- Any other reports as requested by the Chairperson of the SC or BTC.

**Qualifications**

- Academic graduation in Informatics or environment from a recognized national University;
- At least 7 years of professional experiences in using databases and/or geographical information systems;
- At least 2 years of professional experiences in programming water and/or climate change related databases and geographical information systems;
- Minimum 2 years regional experience working in Viet Nam with government and cooperation projects;
- Professional experience in:
  - SQL, MySQL, HTML, PHP, AJAX, Java, JavaScript, Visual Basic, C++, MS Access
  - experience in creating and managing SHAPE-files
  - Use of ArcView, ArcGis
  - Network application like Linux, Microsoft NT, Novell, Apache 2.2.x
  - PostgreSQL 8.x, PostGIS, MapServer
  - MapObjects and ActiveX
  - Computer Hardware, Server Technology
  - Proofed experience in programming Hydro(geo)logical databases
- Professional experience in international cooperation projects;
- Expertise in writing mission reports and other types of publications, proven writing skills in English;
- Good English skills, spoken and written;
- Ability to communicate;
- Ability to work in team.

### **7. 2. 7 National town-planning advisor**

Duty station: Hanoi city with frequent travels to Ha Tinh, Binh Thuan and Ninh Thuan provinces – Vietnam

Duration of the assignment: 30 months, at the start of the study phase of the project

Recruited by BTC

#### **Tasks**

The National town-planning advisor (NTPA) will function on a full-time basis as technical advisor. H/she will be recruited at the start of the study phase of the 3 provinces projects. The NTPA will work in close coordination with the project Vietnamese Coordinator and the project co-leader (international advisor). Reporting to the TSU direction the NTPA shall:

- Support the 3 provinces to gather and analyse data related to urban development issues;
- Collect and analyse possible urban planning strategic plans and policies designed at regional or provincial levels in Vietnam or in nearby or similar countries and which could be used to draft adapted documents for the program;
- Support the development of a comprehensive and detailed strategy to collect and analyse meteorological, climatic and water management data to guide the spatial planning process within the three provinces;
- Based on an in-depth assessment, support the development of a comprehensive training programme on sustainable urban development, strategic structural planning and climate change for the three provinces;
- Give advice on the ways meteorological data and climate change modelling should influence the urban planning and water management processes within the three provinces;
- Contribute to the elaboration of a comprehensive and realistic adaptations and mitigation measures related to water management and urbanisation to be applied in the three provinces with priorities;
- Identify the relevant legal and strategic framework related to urban development and climate change, provide a critical analysis of this framework and identify possible gaps;
- Translate in concrete terms how the climate change and urban development issues (related to both adaptation and mitigation measures) should be communicated to public authorities, the private sector and the local communities and elaborate an action plan to

be implemented by the programme;

- Collect and review technical documents related to adaptation of human settlements and housing to natural disasters and climate change and propose appropriate solutions to the specificities of the 3 provinces;
- Assist the PCUs and the local organization in charge of the saving and credit program to deliver technical assistance to the target communities to upgrade their assets;
- Assist local authorities and PCUs, in writing appropriate terms of references related to his/her field of expertise;
- Support local authorities and PCUs in the supervision of the consultants in charge of the master plan revision;
- Support the organisation of national and/or regional workshop(s) to provide feedback on the study and gather reflections and input from Vietnamese and International partners;
- Contribute to the writing of different reports and concept notes;
- Any other reports as requested by the Chairperson of the SC or BTC.

**Qualifications**

- University degree in architecture and town-planning;
- Experience in implication of the climate change issues into the urban planning process;
- At least 10 years of relevant experience in territorial planning and urban planning;
- Knowledge of strategic structural planning, sustainable urban development, energy efficiency buildings;
- Professional experience in international cooperation projects;
- Expertise in writing mission reports and other types of publications, proven writing skills in English;
- Good knowledge of development projects formulation, evaluation and/or implementation;
- Ability to communicate; and,
- Ability to work in team.

### 7. 2. 8 National IWRM advisor

Duty station: Hanoi city with frequent travels to Ha Tinh, Binh Thuan and Ninh Thuan provinces – Vietnam

Duration of the assignment: 60 months, at the start of the study phase of the project

Recruited by BTC

#### Tasks

The National Integrated Water Resources Management advisor (NIWRMA) will function on a full-time basis as technical advisor. H/she will be recruited at the start of the study phase of the 3 provinces projects. The NTPA will work in close coordination with the project Vietnamese Coordinator (VC) and the project co-leader (international advisor). Reporting to the TSU direction the NTPA shall:

- Support the 3 provinces to gather and analyse data related to IWRM issues;
- Collect and analyse possible IWRM plans and policies designed at regional or provincial levels in Vietnam or in nearby or similar countries and which could be used to draft adapted documents for the program;
- Support the development of a comprehensive and detailed strategy to collect and analyse meteorological, climatic and water management data to guide the spatial planning process within the three provinces;
- Based on an in-depth assessment, support the development of a comprehensive training programme on IWRM, hydrology, climate change for the three provinces;
- Give advice on the ways meteorological data and climate change modelling should influence the urban planning and water management processes within the three provinces;
- Contribute to the elaboration of a comprehensive and realistic adaptations and mitigation measures related to water management and urbanisation to be applied in the three provinces with priorities;
- Identify the relevant legal and strategic framework related to IWRM and climate change, provide a critical analysis of this framework and identify possible gaps;
- Translate in concrete terms how the climate change and IWRM issues (related to both adaptation and mitigation measures) should be communicated to public authorities, the private sector and the local communities and elaborate an action plan to be implemented by the programme;

- Collect and review technical documents related to IWRM and climate change and propose appropriate solutions to the specificities of the 3 provinces;
- Assist local authorities and PCUs, in writing appropriate terms of references related to his/her field of expertise;
- Assist the Basin Committee of the 3 provinces to develop appropriate adaptation activities in coordination with PPC;
- Support local authorities and PCUs in the supervision of the consultants in charge of the hydraulic and climate change studies and modelling;
- Review of basic / detailed designs, drawings, bid documents and cost estimates for the investment projects including assistance to the PCUs in writing ToRs for local design and construction supervision consultancies, preparing specifications and bid documents for construction of investment works and equipment supply, advice during bid evaluation, contract award and implementation of investment projects;
- Support the organisation of national and/or regional workshop(s) to provide feedback on the study and gather reflections and input from Vietnamese and International partners;
- Assist in development of projects planning, coordination, implementation and M&E/reporting frameworks and monitor progress of investment projects;
- Contribute to the writing of different reports and concept notes;
- Any other reports as requested by the Chairperson of the SC or BTC.

**Qualifications**

- MSc or higher educational degree in water resource related engineering, with post-graduate management training;
- At least 10 years of relevant experience in Water Resources Management;
- Knowledge of strategic structural planning, sustainable urban development, energy efficiency buildings;
- Experience in climate change related issues;
- Professional experience in international cooperation projects;
- Expertise in writing mission reports and other types of publications, proven writing skills in English;
- Good knowledge of development projects formulation, evaluation and/or implementation;
- Ability to communicate; and,
- Ability to work in team.

## **7. 2. 9 National community and communication advisor**

Duty station: Hanoi city with frequent travels to Ha Tinh, Binh Thuan and Ninh Thuan provinces – Vietnam

Duration of the assignment: 36 months, at the completion of the study phase of the project

Recruited by BTC

### **Tasks**

The National community and communication advisor (NCCoA) will function on a full-time basis as technical advisor. H/she will be recruited at the completion of the study phase of the 3 provinces projects. The NCCoA will work in close coordination with the project Vietnamese Coordinator (VC) and the project co-leader (international advisor). Reporting to the TSU direction the NCCoA shall:

- Collect and analyse possible community participation and communication plans and policies designed at regional or provincial levels in Vietnam or in nearby or similar countries and which could be used to draft adapted documents for the program;
- Support the development of both communication and community and private sector participation strategies of the program and their detail application within the 3 provinces;
- Based on an in-depth assessment, support the development of a comprehensive training programme on communication, gender, community involvement and participatory planning for the three provinces;
- Give advice on the ways communities and the private sector should influence the urban planning and water management processes within the three provinces;
- Contribute to the elaboration of a comprehensive and realistic adaptations and mitigation measures related to water management and urbanisation to be applied in the three provinces with priorities;
- Identify the relevant legal and strategic framework related to participatory planning, community and private sector involvement, gender and communication, provide a critical analysis of this framework and identify possible gaps;
- Translate in concrete terms how the climate change and urban development issues (related to both adaptation and mitigation measures) should be communicated to public authorities, the private sector and the local communities and elaborate an action plan to be implemented by the programme;
- Collect and review technical documents related the related fields and propose

- appropriate solutions to the specificities of the 3 provinces;
- Assist the PCUs and all related stakeholders to develop the communication strategy, the awareness campaigns and the set-up the saving and credit program in the 3 provinces;
  - Assist local authorities and PCUs, in writing appropriate terms of references related to his/her field of expertise;
  - Support local authorities and PCUs in the supervision of the consultants and organizations in charge of the awareness campaigns and saving and credit scheme;
  - Support the organisation of national and/or regional workshop(s) to provide feedback on the study and gather reflections and input from Vietnamese and International partners;
  - Contribute to the writing of different reports and concept notes,
  - Any other reports as requested by the Chairperson of the SC or BTC.

**Qualifications**

- University degree in social science and communication;
- Experience in implication of the climate change issues into the urban planning process;
- At least 10 years of relevant experience in community participation activities, saving and credit schemes, awareness campaigns;
- Professional experience in international cooperation projects;
- Expertise in writing mission reports and other types of publications, proven writing skills in English;
- Good knowledge of development projects formulation, evaluation and/or implementation;
- Ability to communicate; and,
- Ability to work in team.



## 7. 2. 10 Responsible of Administration and Finance

Duty station: Hanoi city

Duration of the assignment: 72 months

Recruited by BTC

### Tasks

The financial officer is responsible for a variety of finance-related tasks including the ones listed below (this list is not exhaustive). He/she works under direct supervision of the ITA for all own-management-related expenses and of both the Coordinator and the ITA for all co-management-related expenses.

He/she will be one of the members of the PCU, and will work on a full-time basis.

Responsible for financial administration and procedures;

- Control all financial administration issues: solves problems, helps improve financial administration by developing tools, points out and corrects errors and problems, reports any major problem to the co-directors and seeks advice from the LAF when necessary;
- Supervise compliance with legal and administrative procedures and guidelines; this implies he/she studies, checks and reinforces financial guidelines and procedures of the Belgian Technical Co-operation (for Regie) in addition to the Vietnamese regulations (for co-management), including the Specific Agreement, the TFF and any guidelines provided from Brussels or the Representation in Hanoi;
- Ensure all instructions received from the representation or BTC headquarters are correctly applied and followed and that the requests are met within the deadline;
- Update guidelines and system of all types of payments in project, especially allowances;

### Banking & cheque and cash management

- Prepare, register and keep cheques;
- Ensures all invoices from external parties (contractors, suppliers...) are paid in due time, by bank transfer, cheque or cash and arrange those documents by date: her/his task of preparing bank transfer and cheque documents and manage pipeline payment to external parties;
- Check and approve document requested by the financial manager;
- Attend and record all bank transactions, maintain bank accounts, ensure monthly bank

statements and account overviews;

- Final responsibility for the cash management;
- Ensure liquidation of any internal advances and update advance outstanding by the end of each month and report to financial manager;
- Responsible for sound cash planning & cash withdrawals, so as to avoid cash shortages or large amounts cash in safe (security issue);
- Updates fixed asset register, follow up consultancies, contractor contract and stock of stationary.

#### Financial activity reporting

- Record all project expenses properly in the accounting software, following guidelines and within the deadlines the latest 15th of the following month;
- Produce financial statements for control by PCU management/financial manager, make all necessary corrections and make all preparations for the monthly closing of the accounting;
- Supervise daily entry of expenses in the cashbook;
- Check and control to ensure quality and completeness of justification and supporting accounting documents of all expenses following guidelines;
- Ensure accounting coding and budgeting lines are corrects: this includes verification of financial reports, expenses and supporting documents;
- Ensure monthly balance of Cashbooks/Cashboxes and bank statements are the same, and responsible for completion and approval of reconciliation statements if any;
- Responsible for transparent and consistent filing of all accounting, banking and cash management documents.
- Final responsibility for timely production of FIT statements; provide guidance and supervision to the accountant who produces the FIT statements;
- Produce financial reports whenever requested following format laid out (e.g. for steering committees), or develops customized formats for ad hoc reports (in excel);
- Make electronic back-up of final versions of financial reports.

#### Budgeting and financial planning

- Follow up and update of budget; Compare budget and planning with actual expenses; Provide monthly overview of budget balance to co-management and technical teams;
- Financial short-and long term planning: overall, yearly and quarterly (in co-operation with co-management and technical teams); monthly and weekly, in co-operation with

12/2/15  
12/2/15

accountant and financial administrator/logistics assistant;

- Overall management of bank and cash accounts, making cash calls on basis of the financial planning.

#### Auditing, monitoring, consulting, training

- Audit and analyze project expenses monthly, report any inconsistencies or irregularities;
- Control supporting accounting documents on quality and completeness, and follow up on corrections by the accountant;
- Consult and monitor financial issues related to technical project components (e.g. transfer of scholarship funds, accountability of beneficiaries and institutions);
- Prepare and provide training on financial management for stakeholders;
- Preparing and assisting internal and/or external financial audit missions;
- Any other tasks reasonably requested.

#### **Qualification**

- University degree in finance, business administration or business economics;
- Minimum 5 years experience in financial management and project administration;
- Management experience, and experience with an international organization or NGO;
- Very good hands-on knowledge of excel and word is a must. Other programs (Database, accounting programs) a strong advantage;
- Proficient in English and Arabic with good translation skills;
- Mature, good communicator and team-player;
- Able to work under stressful conditions and not objecting to overtime and field missions.

